

Crusader 5800 & 5810

Owner's Manual

Single-Tank Pro, Deluxe & Enhanced

2019 Model Year

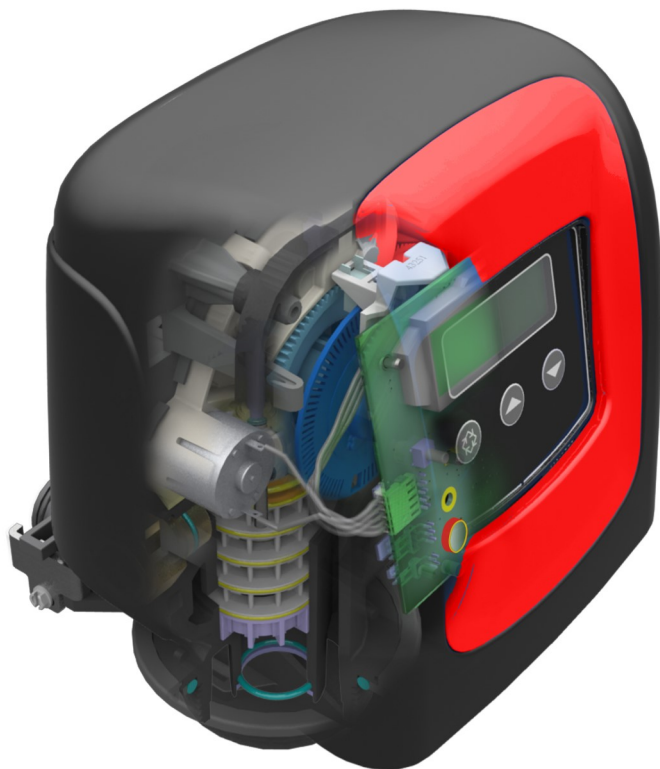

CrusaderWater.com

Table of Contents

Page 4	Warnings & system operational requirements
Page 5	System features & benefits
Page 9	Your responsibilities as an equipment owner
Page 10	ProGuard, Cleaning and Disinfection
Page 11	System installation & start-up guidelines
Page 12	Installation and startup checklist
Page 13	Understanding your controller - SXTi
Page 14	System programming - SXTi
Page 15	Error Codes—SXTi
Page 18	XTR2 Controller Programming and Diagnostics
Page 32	System control & operation
Page 34	Understanding how your system operates
Page 39	System troubleshooting guidelines
Page 43	Exploded parts diagrams
Page 54	ProGuard and ProGuard Feeder
Page 55	Recommended cleaning & disinfection schedule
Page 56	System warranty



This Product is Made with Pride In The United States of America



Each 5800/5810 Valve is Tested and Certified by the WQA to NSF/ANSI Standard 44 & 372 for material safety and structural integrity & lead free compliance as well as CSA B483.1.

CrusaderWater.com

Warnings & System Operational Requirements

The Crusader Water Quality Management System incorporates cutting-edge technology to bring you water that is perfectly soft, and free of inorganic minerals.

Your system is designed to address certain impurities in your water through the process of salt-based ion exchange.

Your system should only be installed on water that is microbiologically safe. To ensure best performance, and maintain warranty compliance, the following installation requirements should be met:

	Minimum	Maximum
Water Temperature	30 F	75 F
Water Pressure	30 psi	75 psi
Influent Water Hardness	0 gpg	100 gpg*
Influent pH	6.7	8.7
Influent TDS	10 ppm	1000 ppm*
Pathogenic Bacteria	N/A	0 CFU
Chlorine	0 ppm	3 ppm
Chloramine	0 ppm	1 ppm
Ambient Temperature	40 F	120 F

* Influent water hardness levels above 22gpg and TDS above 500ppm will negatively impact the taste of the water



Do not use with water that is unsafe or of unknown quality.
Test water periodically to verify that the system is performing satisfactorily.
Discard small parts remaining after installation.



Read and follow the information in this manual to minimize the risk of electric shock or personal injury.
If you are unsure about the installation of your system, contact technical support, a professional plumber, or certified water specialist.
This system must be installed in compliance with applicable state and local codes, applicable law, and regulations.



To bypass the system, turn bypass knob on both sides of the valve to bypass position. When returning to service, put the inlet into service before the outlet.

System Features & Benefits

By purchasing a Crusader Water Quality Management System, you can now enjoy clean, softened water utilizing robust water treatment technologies.

Efficient

The Crusader System learns your lifestyle and quickly adapts itself to meet your needs, delivering exceptional water quality while saving you salt, water and electricity. The highly sensitive digital flow-meter installed in your System allows it to learn how much water you use and when you use it; adjusting reserves and salt consumption to match your water-usage lifestyle and minimize bacterial growth.

Upgradeable

Designed for the future, your Crusader System is capable of being modularly upgraded, as new technologies are developed to accommodate for rapidly degrading water conditions. The onboard control center can be updated with the latest software updates & upgrades as they become available.

Reliable

The mechanical subsystem in each Crusader System is revolutionary in its own right. The Crusader Water Quality Management System is built around Open-platform™ technology, building on a 40-year legacy of reliable design and using 21st century composite materials to ensure reliable and dependable performance.

Safe

Every Crusader System is handcrafted in the USA by skilled artisans in a world-class facility to provide you with a water treatment system that exceeds industry safety, manufacturing & quality control standards to give you peace of mind.

Simple

Advanced manufacturing methods and skillfully crafted computer hardware & software makes a Crusader Water Quality Management System one of the easiest water quality improvement systems to own and operate.

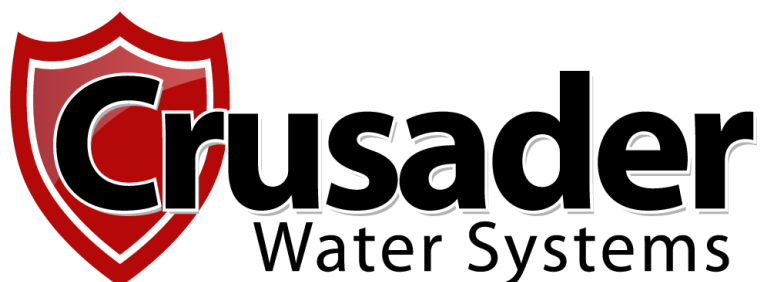

System Components (Pro Model)

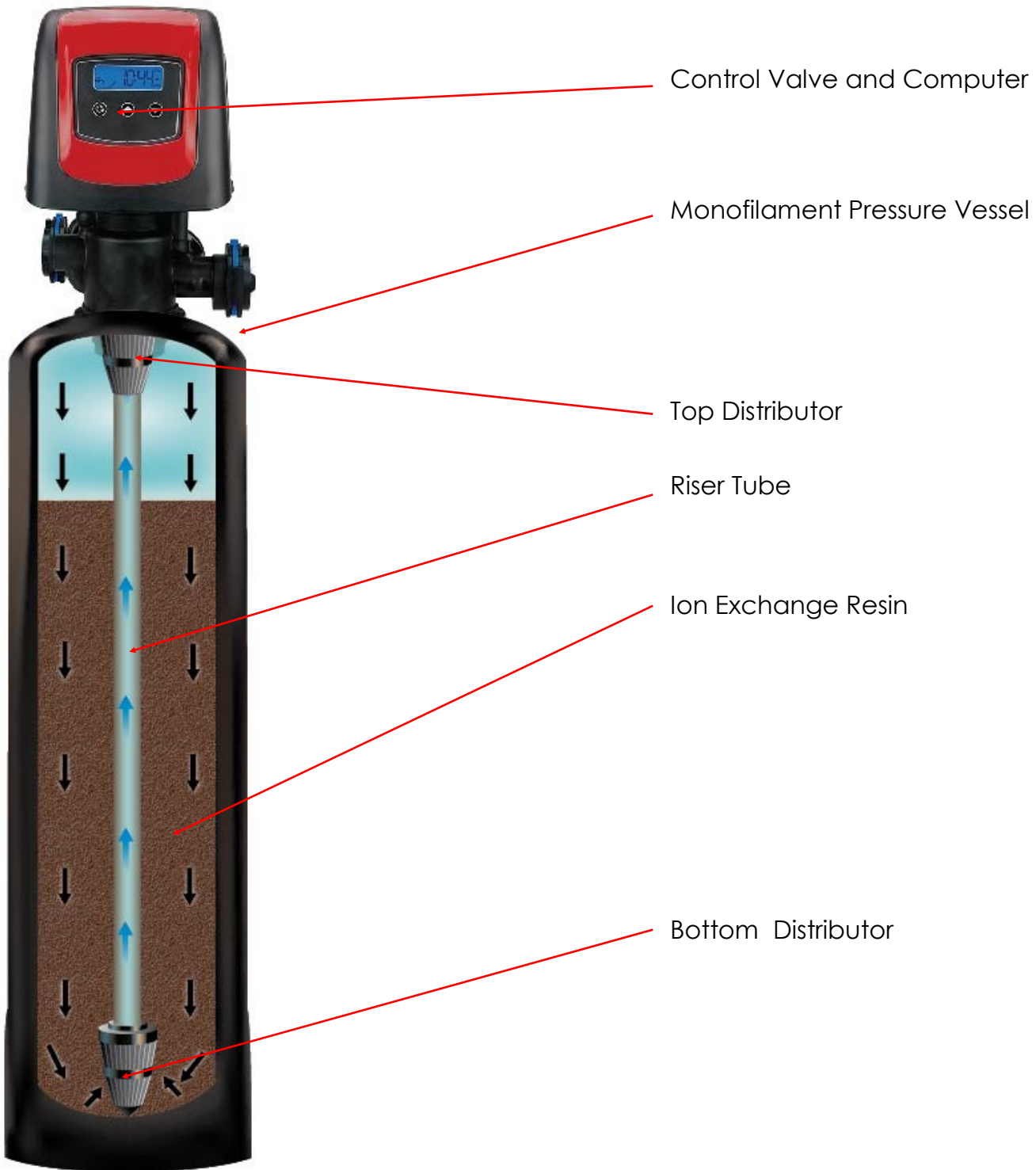

	<p>The System must be BYPASSED, DEPRESSURIZED and DE-ENERGIZED before disassembling or performing mechanical repairs</p>		<p>Disassembly, Repair/Replacement/ Reassembly should only be performed by properly trained service personnel</p>
--	---	--	---

System Components (Deluxe Model)

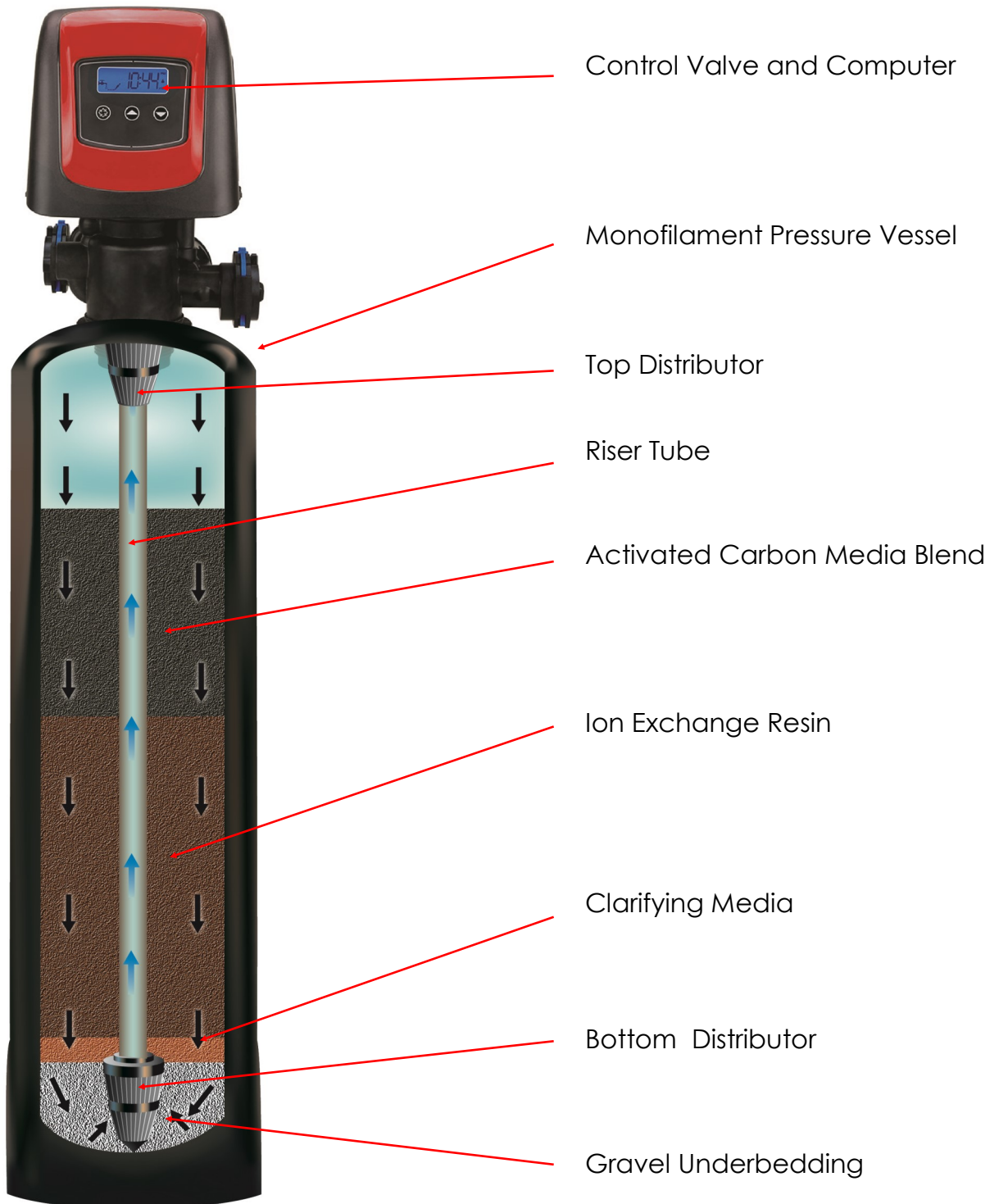

The System must be **BYPASSED, DEPRESSURIZED and DE-ENERGIZED** before disassembling or performing mechanical repairs



Disassembly, Repair/Replacement/ Reassembly should only be performed by properly trained service personnel

System Components (Enhanced Model)

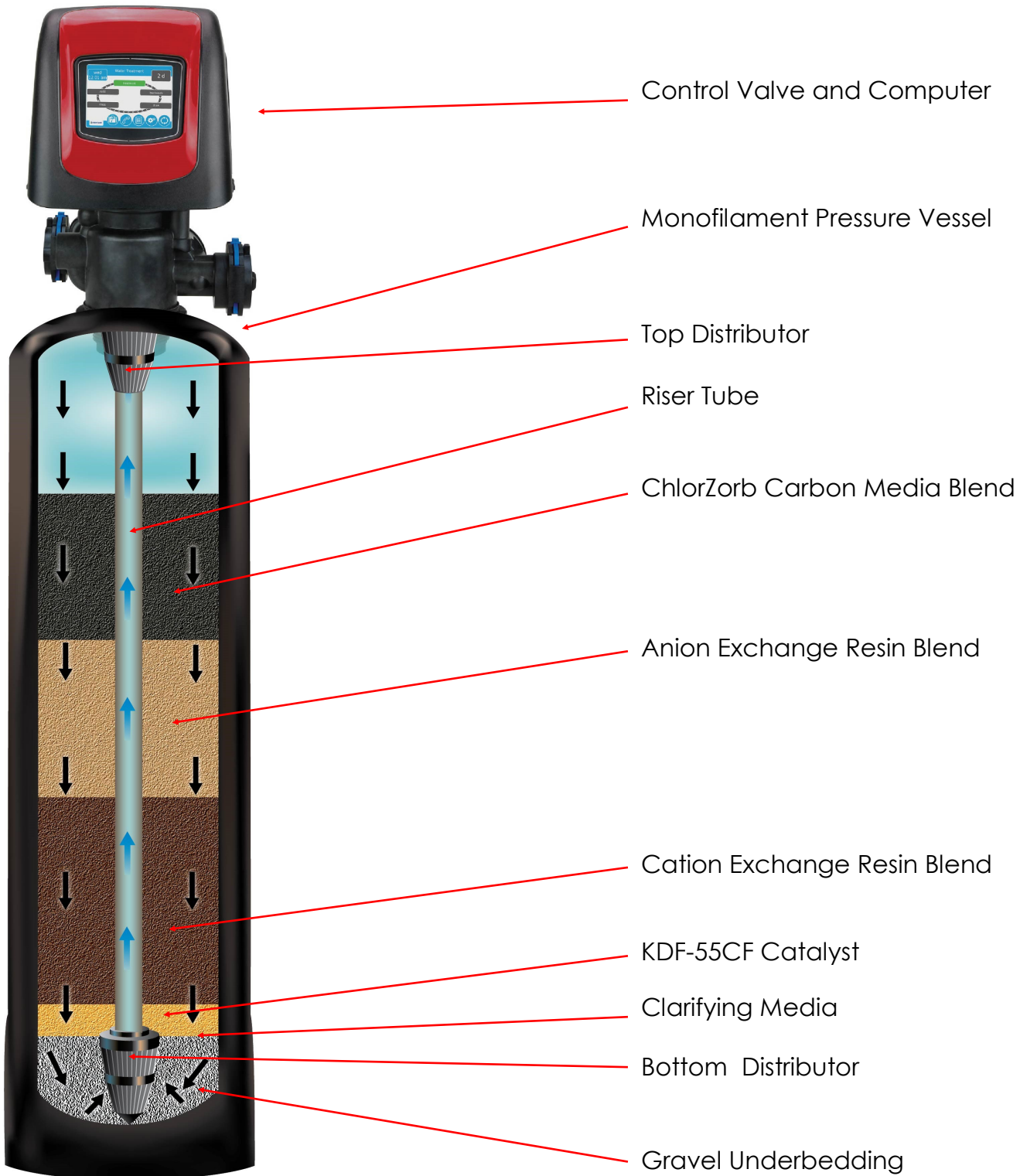

	<p>The System must be BYPASSED, DEPRESSURIZED and DE-ENERGIZED before disassembling or performing mechanical repairs</p>		<p>Disassembly, Repair/Replacement/ Reassembly should only be performed by properly trained service personnel</p>
--	---	--	--

Your responsibilities as an equipment owner

Your Crusader Water Quality Management System is manufactured to be efficient and reliable.

To ensure continued performance while keeping your system operating within manufacturer's specifications, the following operating conditions must be ensured by you, the equipment owner/operator:

Water Pressure Regulator

The influent water pressure into this water system must be regulated by a code-compliant pressure-regulating device not to exceed 75 psi.

Power Protection

Power to this system must be supplied by an unswitched 110VAC supply. Surge protection is mandatory and is to be supplied by you, the equipment owner. The use of a UPS (Uninterruptible Power Supply) is encouraged.

Salt

This water system uses either sodium or potassium salt to clean itself. The brine tank must be filled with a high quality salt to ensure proper system operation. Consult with your local water professional to decide on the best salt for your area.

ProGuard

The ProGuard reservoir should be kept full to ensure proper system operation and maximum efficiency. ProGuard works synergistically with the Softening media to ensure the very best water feel and to maximize cleaning power. Check the level of your ProGuard feeder each time you fill your brine tank with salt.

Periodic replacement of media

While built to the highest standards, certain media in your Crusader Water Quality Management System will need to be replaced periodically.

Replacement intervals vary depending on your water chemistry and water consumption habits. Consult with your local water specialist to ensure that you always enjoy the very best water quality.

ProGuard

The ProGuard™ feeder incorporated into every Crusader System ensures that you have the best water quality all year long. This simple dispensing system is specially engineered to work in all climates to easily introduce ProGuard into your brine tank while the system is waiting to clean itself.

Your Crusader System will use varying amounts of ProGuard, depending on your water consumption habits; always maximizing efficiency and performance while providing you with the water quality that you deserve.

ProGuard is designed to:-

- Clean ion-exchange resin without damaging structured matrix media
- Clean all moving parts & create a temporary protective coating
- Create an unhealthy environment for bacteria in the system
- Remove oils and other hydrocarbons from resin
- Clean Activated Carbon Media
- Enhance self-sanitization processes on compatible systems

Always keep your ProGuard reservoir full to ensure proper system performance, longevity & efficiency.

Cleaning and Disinfection

Your Crusader Water Quality Management System is quite probably the hardest working appliance in your home, processing millions of gallons of water over its service life and in turn protecting you from countless amounts of inorganic calcium, magnesium, lead, copper, zinc, iron, manganese, and other contaminants that could be in your water.

In addition to capturing inorganic contaminants, your softener also accumulates sediment, bacteria, algae, mold, and fungus that can enter the system through safe city water, salt, or even from the air. These additional contaminants slowly accumulate in your softener and can even colonize it with a biofilm of Heterotrophic Plate Count (HPC) bacteria. These bacteria are usually benign, but they can create a food base as safe refuge for potentially harmful pathogens and seriously compromise the longevity and performance of your system. While weekly antibacterial rinses and supplementation with ProGuard help minimize bacterial growth, your system should also be cleaned and disinfected on a regular schedule to ensure that it is working to the best of its ability and to protect the safety of your family.

Your local dealer can perform the cleaning and disinfection service for you, or you can purchase a comprehensive cleaning and disinfection kit to perform this task yourself.

System Installation & Start-up Guidelines

Clear the installation area and carefully sweep the floor where the system will be installed.

Test incoming water pressure and make sure it is 30 – 75 psi static. A code-compliant pressure regulator must be installed to protect the system on all municipal water installations.

Check to confirm that the water heater has adequate heat expansion protection.

Install the system, drain and brine tank overflow according to manufacturer's instructions and prevailing local code.

Bypass System.

Run bathtub cold to purge piping of debris and chemical residue from installation,

This will take approximately 5 minutes at 3 gpm.

Leave bathtub running and slowly open the inlet valve to the system.

Slowly open the outlet valve from the system.

Observe flow of water from the bathtub. Water will become a dark brown/black color. This color is caused by the system disinfectant/preservative as well as dust from shipping & handling. Allow water to run until clear. Observe water for particles. If resin or other Softening media particles are found in the water, bypass the system and call tech-support. - Leave the bathtub running

Enter programming mode

Program the system to match the installation configuration and operating conditions

Begin a cleaning cycle by pressing the **CYCLE** button and holding for at least 5 seconds.

Advance the system through each cycle step by pressing the **CYCLE** button. Observe the system during each cycle and then progressively advance to the next until the regeneration terminates.

Once the system has been advanced to normal operating mode, observe the flow of water from the bathtub again for disinfectant and resin. Allow water to run clear – Turn off bathtub

Test water at any softened faucet to confirm acceptable water production from the system.

Installation And Startup Checklist

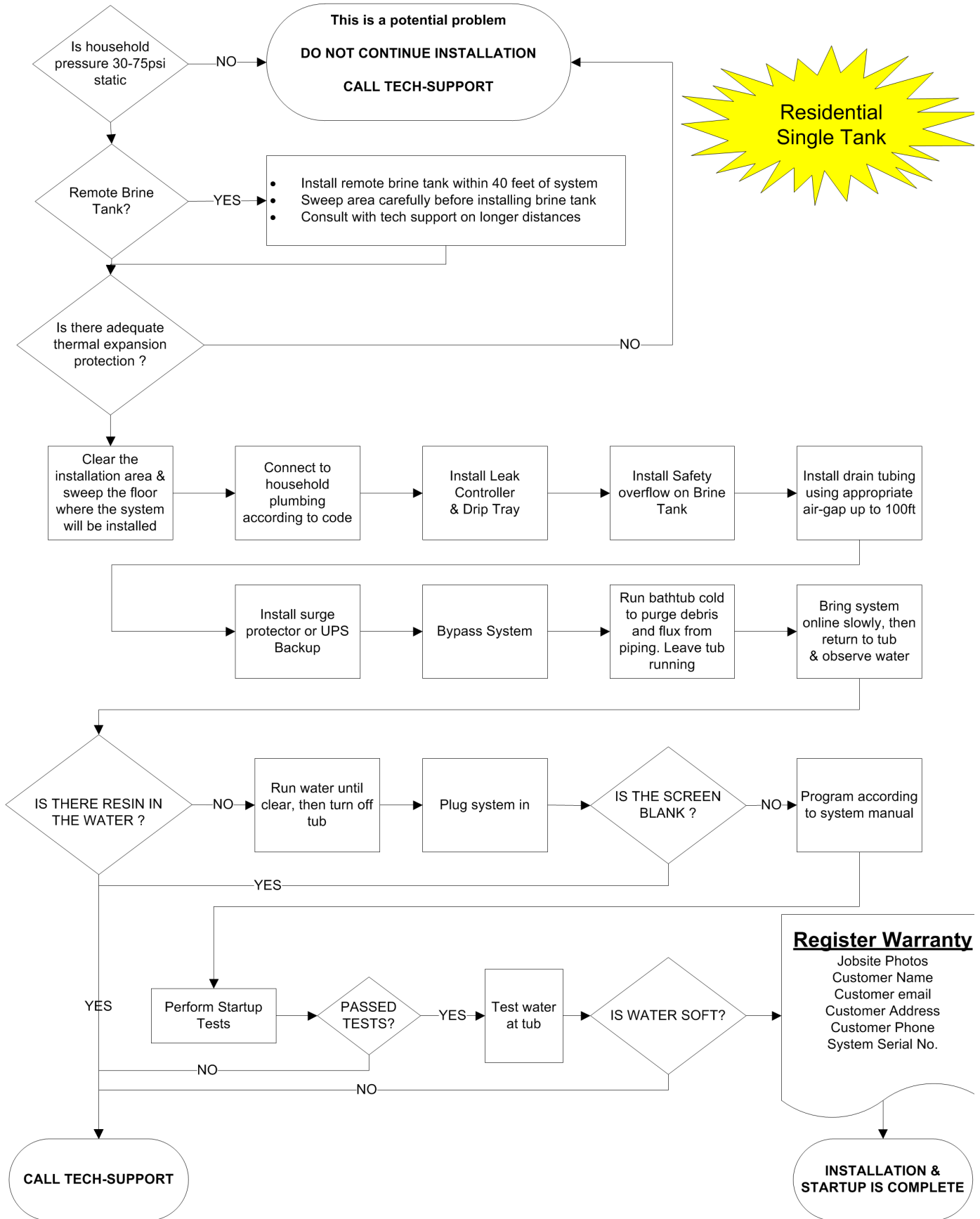

Understanding Your Controller SXTi

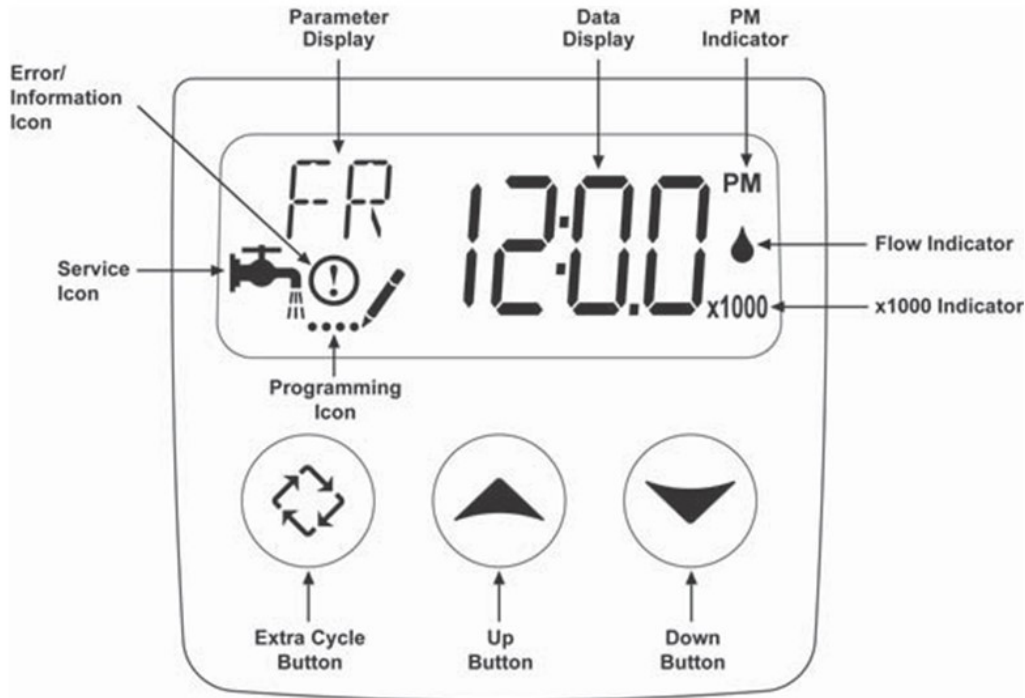

Service Icon:

The Service Icon flashes if an automatic cleaning cycle has been scheduled, or if you request a delayed cleaning cycle.

Error/Information Icon:

Illuminates when the system detects a fault condition.

Parameter Display:

Displays cycle descriptors during cleaning.

Data Display:

Displays cycle times, diagnostic and other information as necessary.

PM Indicator:

Illuminates when the time is afternoon.

Flow Indicator:

Flashes when flow is detected through the system—faster blinking indicates a higher flow rate.

Programming Icon:

Illuminates when the control is in programming mode.

Up & Down Buttons

Adjust digits up or down and select between alternate options when changing system settings.

Extra Cycle Button:

Press once to initiate a delayed cleaning cycle—Press and hold to clean now.

System Programming SXTi

End-user programming is generally not necessary. If you ever need to change programming, the following procedure should be used:-

To Set Time of Day:

Press and hold the **Up** or **Down** button until the PROGRAMMING ICON illuminates.
Make changes with the **Up** or **Down** Button as necessary and press the **CYCLE** button

Accessing the End-User Programming level:

Make sure that the system is in the service mode.
the **UP** and **DOWN** buttons **simultaneously** and **hold for 5 seconds**
Use the **CYCLE** button to alternate between program settings
Use the **UP** and **DOWN** arrows to make changes within individual settings.
Use the **CYCLE** button to exit programming mode, and return to service mode

Available programming parameters:

	Factory Default Setting	Notes
(DO) Day Override	7 Days	Default setting allows your system to clean itself once a week to minimize bacterial contamination. The amount of salt used is related to the amount of water used, If you use no water in that week, the system will use no salt.
(RT) Cleaning Time	11:00 PM	The system will begin cleaning itself at this time. Since it fills and percolates first, the system will not place itself offline until 3 hours after the beginning of the cleaning sequence.
(H) Water Hardness	20 GPG	Your dealer will adjust this to match the results of their testing on your untreated water.

Diagnosics Mode SXTi

Diagnosics mode is accessed as follows:-

Press the **UP and EXTRA CYCLE** buttons simultaneously for 5 seconds.

Press the **UP** button to advance through stored data.

Press the **EXTRA CYCLE** button to exits Diagnosics Mode

FR— Current Flow Rate	The speed at which water is flowing through your system right now.
PF—Peak Flow Rate	The highest flow the system has detected since the most recent cleaning cycle.
HR—Hours in Service	Total number of hours that your system has been in-service
VU—Volume Used	Number of gallons processed through your system
RC—Reserve Capacity	Displays the system's Reserve Capacity calculated from operational and pre-programmed data, as well as your usage habits.
SV—Software Version	Display's the SXTi software version installed on your controller

System Error Codes SXTi

During an error condition, the system will attempt to function as much as possible; at a minimum continuing to monitor the flow meter and update the remaining capacity. Once the error condition is corrected, the system will return to normal operating mode.

If an error is present, a cleaning cycle can only occur manually by pressing and holding the **CYCLE** button for 5 seconds. If the system was in a cleaning cycle when the error occurred, it will complete the regeneration cycle and attempt to return to service.

When the problem is corrected, and the error no longer displays (it may take several seconds for the system to stop displaying the error message), the system will return to normal operation.

Error Code	Cause	Reset and Recovery
0	No state changes in the optical sensor are detected for 6 seconds.	Power Cycle and allow the control to attempt to find position again. Verify the optical sensor is in place with the wires connected to the circuit board. Verify the motor and drive train components are in good condition and assembled properly. Plug the unit back in and observe its behavior. If the error reoccurs, unplug the unit, put it into bypass and contact your dealer.
1	An undesired optical sensor state change occurred.	Non-critical error. Extra optical sensor pulse detected. Press any button to clear the error. Press extra cycle button to advance motor to clear error.
2	The system has not regenerated for more than 99 days	Perform a Manual Regeneration to reset the error code. Verify that the system is measuring flow by running service water and watching for the flow indicator on the display. If the unit does not measure flow, verify that the meter cable is connected properly and that the meter is functioning properly.
3	Control board memory failure.	Perform a Master Reset and reconfigure the system via Master Programming Mode. After reconfiguring the system, step the valve through a manual regeneration. If error continues, call your dealer.
4	Valve has failed to find position in 60 seconds	Unplug the unit and plug it back in. If error continues, Call your dealer.

XTR2 Controller Programming & Diagnostics



TOUCHSCREEN CONTROL QUICK START

The XTR2 control was designed to be easy to set up and begin using right out of the box. The following simple procedure can be used to set up the system and begin treating water in most typical applications.

NOTE: Steps 3 and 4 are optional and are not required to start the system. All control settings may be changed after the unit is in service.

NOTE: Press  on any Quick Start screen to reset the screen back to its default settings.

1. After plugging in the unit, the Format screen (Figure 3) is displayed.

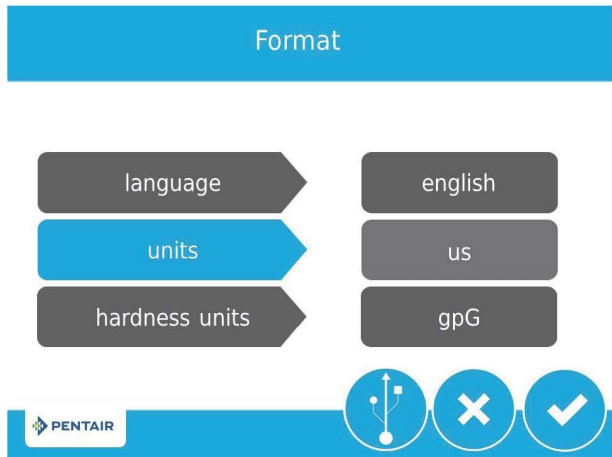



Figure 3 Format Screen

Press the **language** button to adjust the system's displayed language (international version only): English, French, German, Italian, or Spanish. Press  when finished.

Press the **units** button to adjust the system's units of measure (either U.S. or metric). Press  when finished.

Press the **hardness units** button to adjust the system's hardness units of measure (grains per gallon, mg/L or ppm, German degrees, French degrees, or English degrees). Press  when finished. Hardness units are adjustable only if metric units are selected.

NOTE: If the screen is blank after plugging in the unit, touch the screen to turn the screen on.

2. After pressing , the Assistance Name screen (Figure 4) is displayed.

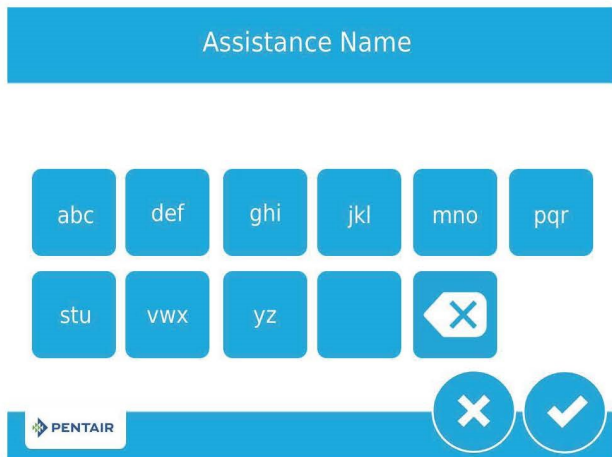



Figure 4 Assistance Name Screen

Using the keypad, type the name of the water treatment professional or company that the homeowner may call for system service (optional).

To enter a letter using the keypad, quickly press the keypad button the number of times that correspond with the position of the correct letter on the button. For example, to enter the letter "C", quickly press the ABC button three times. Press  when finished.

3. After pressing , the Assistance Phone screen (Figure 5) is displayed.

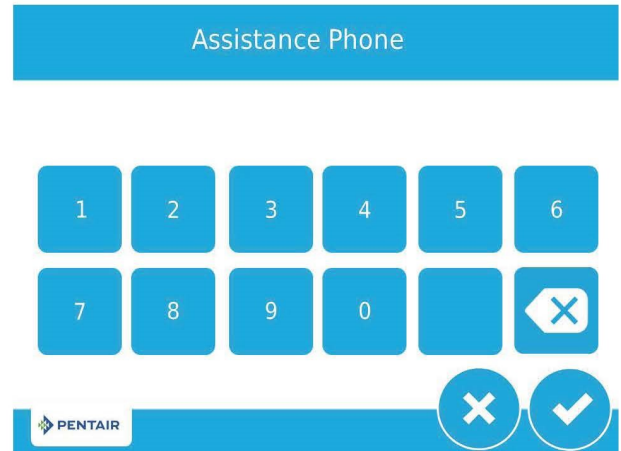



Figure 5 Assistance Phone Screen

Enter the phone number of the water treatment professional or company that the homeowner may call for system service (optional). Press  when finished.

4. After pressing , the Assistance Interval screen (Figure 6) is displayed.

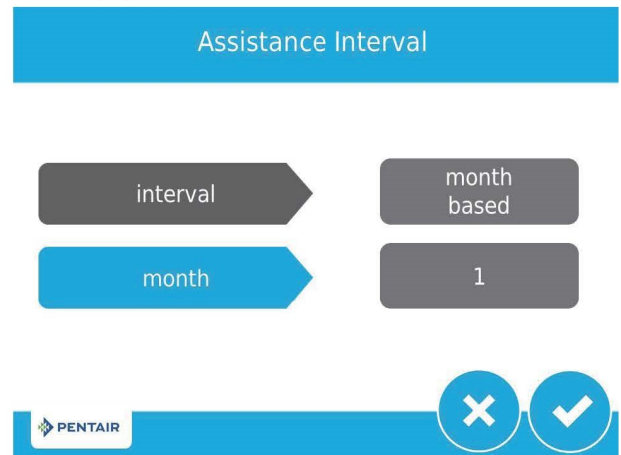



Figure 6 Assistance Interval Screen

Use the Assistance Interval screen to set the interval in which the homeowner will need to call a water treatment professional for system service (optional). The assistance interval can be based on a set number of months (month based) or a number of regenerations (regen based).

Press the **interval** button to select a month-based or regen-based assistance interval, then press . Press either the **month** or **regen** button (depending on your previous selection), and select the number of months (up to 60) or regenerations (up to 2000) until the homeowner will need to call for service. Press  when finished.

TOUCHSCREEN CONTROL QUICK START

continued

5. After pressing , the Home screen (Figure 7) appears.

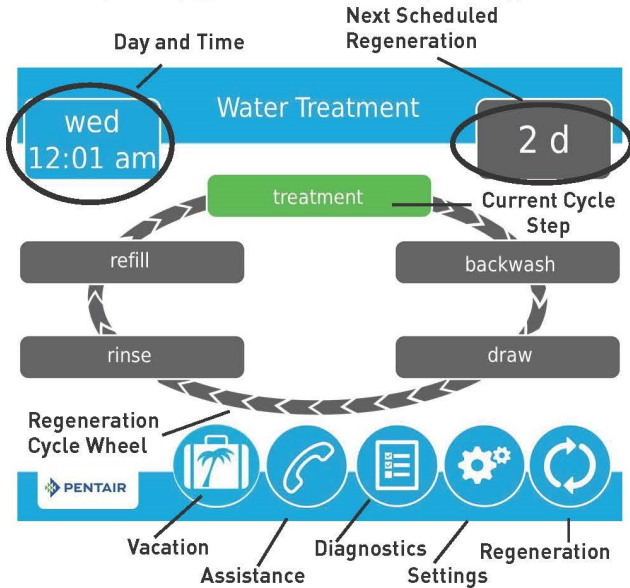

Figure 7 Home Screen

The **Day and Time** button will be flashing, indicating that the day of the week and time need to be set. If the date and time are incorrect, press the **Day and Time** button to update to the correct day and time. The Day and Time screen (Figure 8) appears.

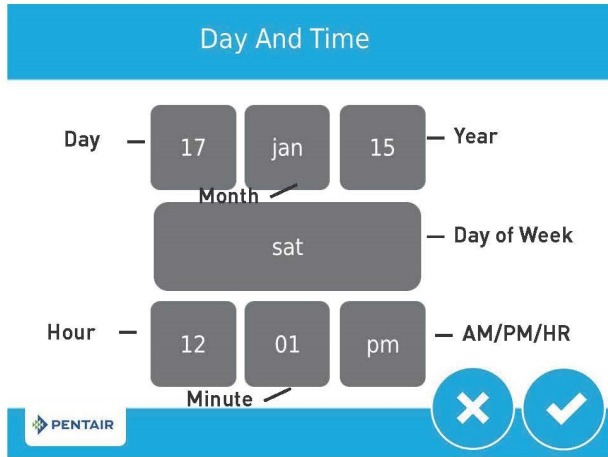





Figure 8 Day and Time Screen

Press the **Day of Week**, **Hour**, **Minute**, and **AM/PM/HR** buttons to adjust the values to the correct day of week and time. Setting the value of the **AM/PM/HR** button to HR changes the display to a 24 hour clock. Press the **Day**, **Month**, and **Year** buttons to adjust the values to the correct date. Press the  button when finished to return to the Home screen. Press  to return to the Home screen without saving.

6. Start a regeneration by pressing the **Regeneration** button . The Regeneration screen appears (Figure 9).

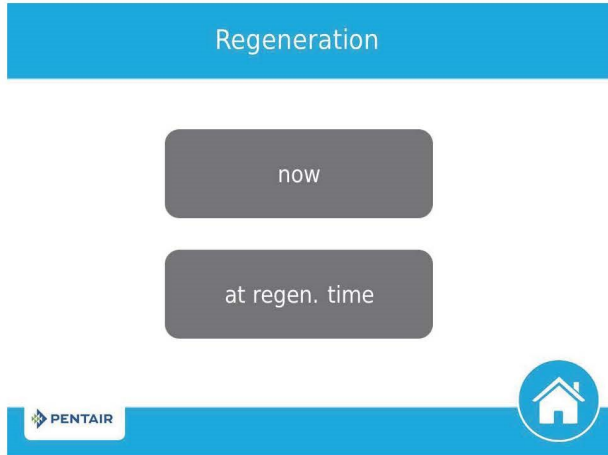

Figure 9 Regeneration Screen

Press the **now** button to begin a regeneration immediately. Cycle through each step and check the system for leaks.

7. For softener systems, put salt in the brine tank.

NOTE: Do not use granulated or rock salt.

The unit is now fully programmed and ready to treat water. This quick setup uses the control's default settings, which are appropriate for most residential applications.

TOUCHSCREEN CONTROL FEATURES

Features of the XTR2 Touchscreen Control

- Full-featured easy to use graphical touchscreen interface for programming, servicing, and diagnostics.
- Non-linear programming no longer requires cycling through every parameter when programming/servicing.

Buttons and Symbols

NOTE: Not all buttons appear on all screens.

Regeneration Cycle Wheel

- Displays the regeneration cycle step the system is currently in. The wheel rotates with each step so that the current step is shown in green.

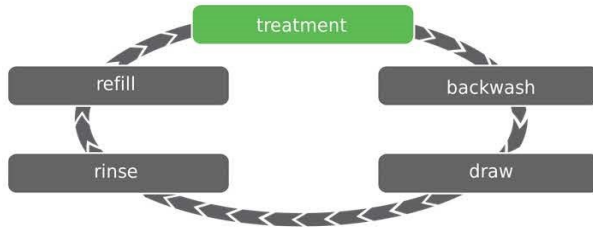

NOTE: On metered units, the "Treatment" step on the Regeneration Cycle Wheel will flash when water is flowing through the unit.

Home



- Displays the Home screen.

Regeneration



- Displays the Regeneration screen, which allows you to start a regeneration and manually cycle through the regeneration steps.

Settings



- Displays the Settings screen, which allows you to adjust commonly used settings. Pressing this button while in the Settings screen provides access to the Master Settings screen, which allows you to fully program the valve.

NOTE: Due to the complexity of these settings and the potential for errors, Master Settings should only be accessed by your local water professional.

Diagnostics



- Displays the Diagnostic screen, which can assist in performing maintenance and troubleshooting performance issues with the valve.

Brightness



- Displays the Brightness screen, which allows for adjustment of the touchscreen display backlight.

Vacation Mode



- Halts all scheduled regenerations when pressed; press again to resume normal operation.

Assistance



- Displays a name and phone number to call for unit service.

USB Connect



- Allows you to connect the control to a PC via a USB cable for field programming or download of diagnostic parameters via PC (Field Programmer application required).

Screen Navigation Arrows



- Displayed in the upper-left and upper-right corners of the screen, these arrows allow you to navigate from one screen to another. **NOTE: Settings on previous screen are not saved unless  is pressed.**

Settings Arrows



- These arrows allow you to change the values of certain settings when programming the control.

Alarm



- Displayed when an alarm has occurred; accompanied with an audible alarm. Press to silence the audible alarm.

Error



- Displayed when an error has occurred. Press to display the Error screen for more detailed error information.

Advance



- This arrow allows you to advance through cycle steps during a regeneration.

Reset



- Displayed in the Diagnostics screen to reset Totalizer and Peak Flow data and in Master Settings to reset parameters to factory or non-factory settings.

Accept



- Press to save or accept changes in control configuration.

Cancel



- Press to cancel configuration and exit to previous screen without saving.

TOUCHSCREEN CONTROL FEATURES

continued

Screen Features

Home Screen

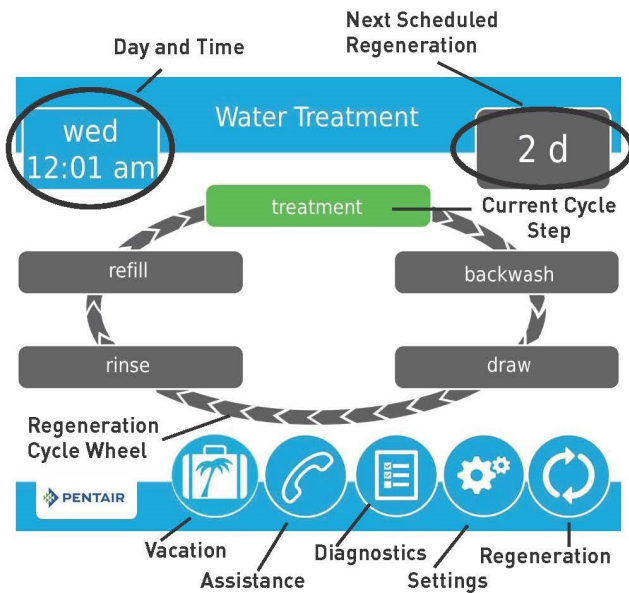

Figure 10 - Home Screen

The Home screen is always displayed unless the control settings are being configured or during regeneration. This screen displays general information about the system and allows you to start a manual regeneration or access control settings. Features of the screen are described below, followed by more detailed information about each feature.

NOTE: If no button is pushed for five minutes, the screen will enter a power save mode. The unit will continue to operate, but the screen will be blank. Touch anywhere on the screen to exit power save mode.

- **Regeneration:** Press to start a manual regeneration.
- **Settings:** Press to access commonly used settings.
- **Diagnostics:** Press to view diagnostic data.
- **Assistance:** Press to display the name and phone number to call for service.
- **Vacation Mode:** Press to halt all scheduled regenerations; press again to resume normal operation.
- **Regeneration Cycle Wheel:** Displays the cycle steps the valve will step through during a regeneration; the current cycle step is always at the top of the wheel.
 - **Treatment:** The unit is treating water
 - **Backwash:** Water flows from the bottom of the vessel to the top of the vessel to clean the media
 - **Draw:** Brine is drawn into the media and then slowly rinsed out
 - **Rinse:** Water flows from the top of the vessel to the bottom of the vessel to rinse the media
 - **Refill:** Brine tank is refilled with water
- **Next Scheduled Regeneration:** Displays the time to next scheduled regeneration, or volume remaining until regeneration in meter systems.

- **Day and Time:** Displays the currently programmed day of the week and time. This button will flash if the control has been reset.

Regeneration

Regenerate the system on demand by pressing the Regeneration button on the home screen. Manual Regeneration can only be used while the valve is in the treatment position. From the Home screen, press the **Regeneration** button . The Regeneration screen appears.

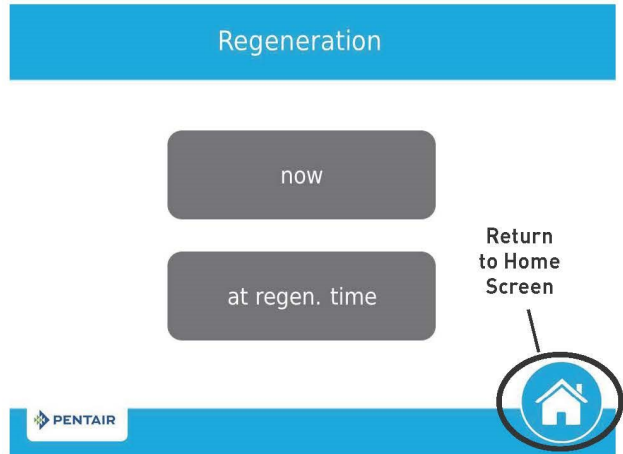

Figure 11 Regeneration Screen

- Press **now** to begin a regeneration immediately, or press **at regen. time** to queue the regeneration for the programmed regeneration time (2:00 AM default for softeners, 12:00 AM default for filters). Pressing **at regen. time** again will cancel the manual regeneration.
- During Regeneration, press the button to immediately advance to the next cycle step. Once in regeneration, the volume or time will be displayed below the button.

Day and Time

From the Home screen (displayed in Figure 10 above) press the Day and Time button. The Day and Time screen appears.

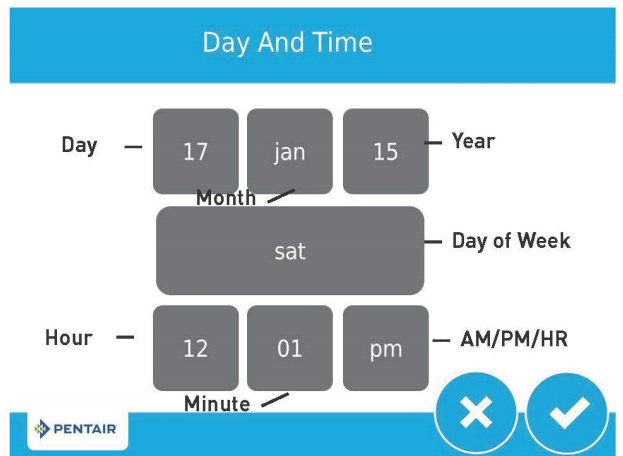

Figure 12 Day and Time Screen

- Press the **Day of Week**, **Hour**, **Minute**, and **AM/PM/HR** buttons to adjust the values to the correct day and time. Setting the value of the **AM/PM/HR** button to HR changes the display to a 24 hour clock. Press the **Day**, **Month**, and **Year** buttons to adjust the values to the correct date. Press the button when finished to return to the Home screen.

TOUCHSCREEN CONTROL FEATURES

continued

Settings

The Settings screen allows you to change basic control settings including time of regeneration and water hardness. These settings improve the operational efficiency of the system and can be adjusted independently from other control settings without needing to enter Master Settings.

From the Home screen, press the **Settings** button . The Settings screen is displayed.

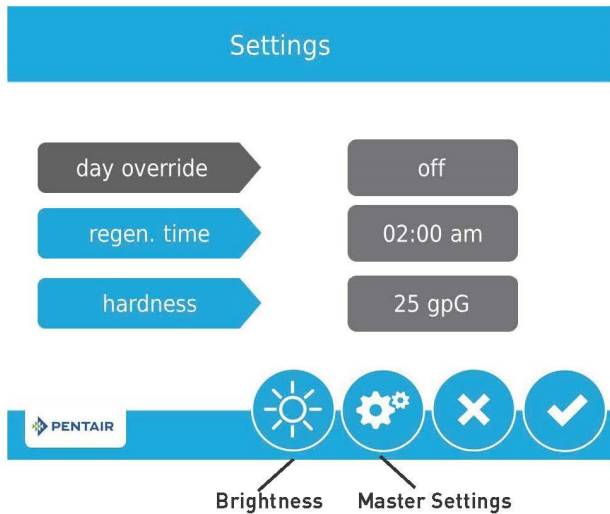

Figure 13 Settings Screen

- Press **day override** to adjust the number of days since last regeneration in which a new regeneration will automatically be run whether one is scheduled or not.
- Press **regen time** to adjust the time of day that an automatic regeneration cycle will begin.
- Press **hardness** to adjust the hardness setting. This value should match the hardness of the incoming untreated water supply.

NOTE: Changing the hardness setting recalculates treatment volume and regeneration interval. This setting should only be changed on the advice of a professional.

- Press  to save your changes or press  to return to the Home screen.

Additional features may be accessed from the Settings screen by pressing the buttons at the bottom of the screen (see Figure 13):

- **Master Settings:** Displays the Master Settings screen, which allows you to fully program the valve.
- **Brightness:** Displays the Brightness screen, which allows you to adjust the backlight brightness of the control screen.

NOTE: Due to the complexity of these settings and the potential for errors, Master Settings should only be accessed by your local water professional.

NOTE: Settings can not be accessed during a regeneration. If a regeneration starts while in the settings menu, the screen will return to the main screen and all parameters will be voided.

User Assistance

The Assistance screen displays the name and phone number that the homeowner may call for service of the unit. Press the **Assistance** button  from the Master Settings or Home screens. The Assistance screen is displayed.

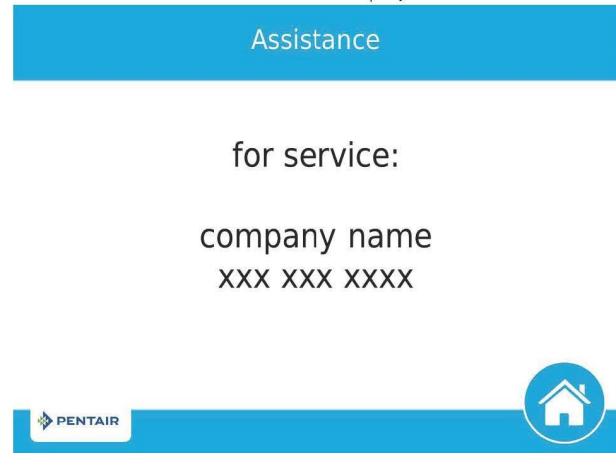

Figure 14 Assistance Screen

- This information is entered upon initial control startup (see TOUCHSCREEN CONTROL QUICK START) or can be changed in Master Settings.
- Press the **Home** button  to return to the Home screen.

NOTE: The Assistance screen is also displayed automatically when the system reaches the programmed assistance interval. See TOUCHSCREEN CONTROL QUICK START.

Master Settings

The Master Settings screens include all configurable parameters available in the control.

CAUTION Improperly adjusting master settings may cause the system to operate incorrectly. Before entering master settings please contact your professional water dealer.

From the Settings screen, press the Settings button . A warning message appears.

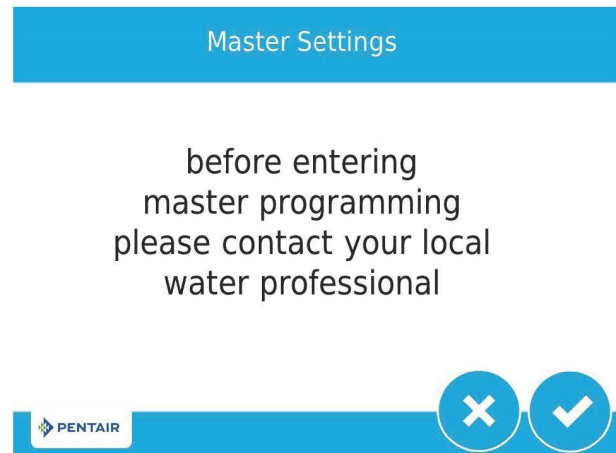



Figure 15 Master Settings Warning Screen

- Press  to continue to the Password screen or press  to return to the Home screen.

TOUCHSCREEN CONTROL FEATURES

continued

The Password screen displays a numeric keypad.



Figure 16 Password Screen

- Enter the master settings password **1201** and press to continue to the main Master Settings screen, or press to return to the Home screen.

After entering the correct password and pressing , the main Master Settings screen is displayed.

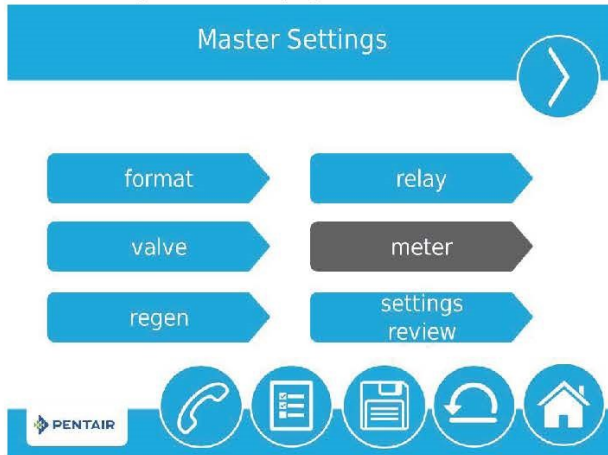

Figure 17 Main Master Settings Screen

While in the Master Settings screens, press to save all set parameters to a custom profile (see "NON-FACTORY SETTINGS" on page 14) or press the **Home** button to return to the Home screen.

Features of the Master Settings screens are described below. See MASTER SETTINGS PROGRAMMING and MASTER SETTINGS REFERENCE CHART for more detailed information.

- **format**: Contains settings for Language, Units, Assistance Name, Assistance Phone, and Assistance Interval. See TOUCHSCREEN CONTROL QUICK START for more information about these settings.
- **valve**: Contains settings for System, Valve, and Regeneration Type.
- **regen**: Contains settings for Regen Flow.
- **relay**: Contains settings for Aux 1 and Aux 2 relays.
- **meter**: Contains settings for Meter Types.
- **settings review**: Displays a summary of all programmed settings.

Press the screen navigation arrow at the top right of the screen to navigate to the secondary Master Settings screen.

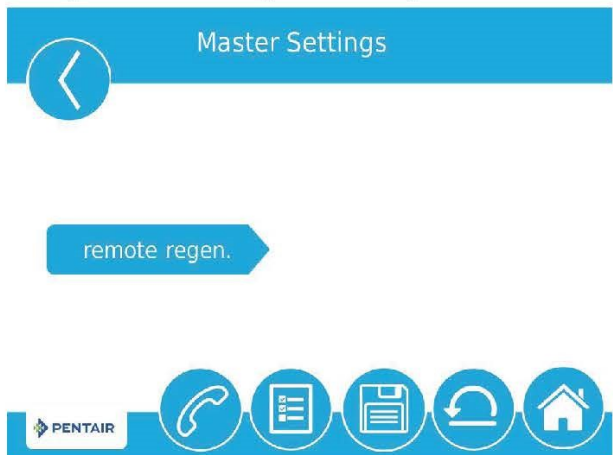

Figure 18 Secondary Master Settings Screen

- **remote regen**: Contains settings for triggering a regeneration via a remote input.

MASTER SETTINGS PROGRAMMING

CAUTION Improperly adjusting master settings may cause the system to operate incorrectly. Before entering master settings please contact your professional water dealer.

NOTE: If a regeneration is scheduled to occur while in Master Settings, the scheduled regeneration will be cancelled.

The following is a detailed overview of settings available in Master Settings. Please see the MASTER SETTINGS REFERENCE CHART for the complete set of values and ranges available to program while in Master Settings.

Format Screen

From the main Master Settings screen (Figure 17) press the **format** button to display the Format screen.

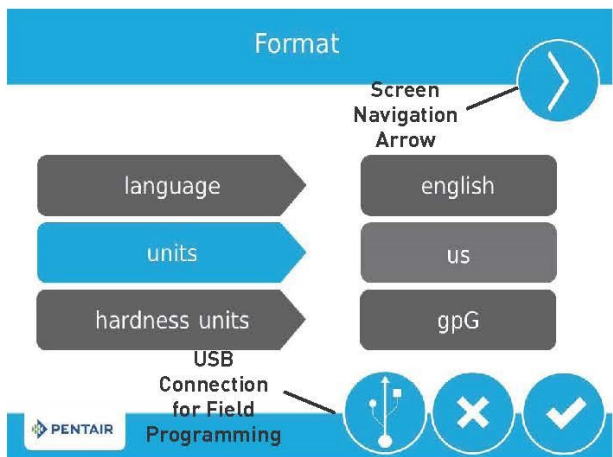



Figure 19 Format Screen

MASTER SETTINGS PROGRAMMING

continued

- **language:** Displays the language used on the control (international version only): English, French, German, Italian, or Spanish.
- **units:** Contains settings for the unit type (either US or Metric) to be used in the control.
- **hardness units:** Contains settings for hardness units of measure (grains per gallon, mg/L or ppm, German degrees, French degrees, or English degrees). Hardness units are adjustable only if metric units are selected.

NOTE: Degree hardness units are converted to ppm upon input. Degree inputs may be rounded up or down to the nearest ppm equivalent.

- Press the screen navigation arrows at the upper-right and left of the screen to navigate to the Assistance Name, Assistance Phone, and Assistance Interval screens. See TOUCHSCREEN CONTROL QUICK START for more information about these settings.
- Press  to save changes.

USB Connection for Field Programming

The XTR2 features a USB port that allows you to connect a PC to the control for field programming and diagnostic parameter download.

NOTE: Field Programmer software is required for field programming features. See XTR2 Field Programmer Manual for more information on using the Field Programmer software.

Pressing  on the Format screen displays the USB screen.

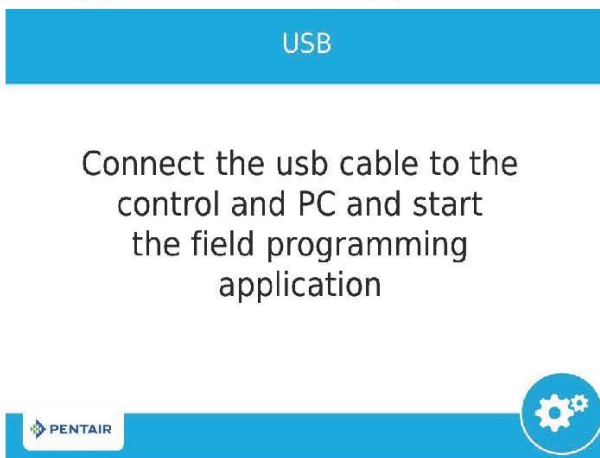



Figure 20 USB Screen

When the USB screen appears, connect a USB cable to the USB port on the control circuit board [see "WIRING DIAGRAM" on page 27 for location of USB port]. connect the other end of the USB cable to a PC with the Field Programmer software installed and follow the directions in the XTR2 Field Programmer manual to complete the connection. Press  to return to Master Settings.

NOTE: Do not remove USB cable from computer or control while connected and transferring data. See the XTR2 Field Programmer manual for proper disconnection procedure.

Valve Screen

From the main Master Settings screen (Figure 17) press the **valve** button to display the Valve screen.

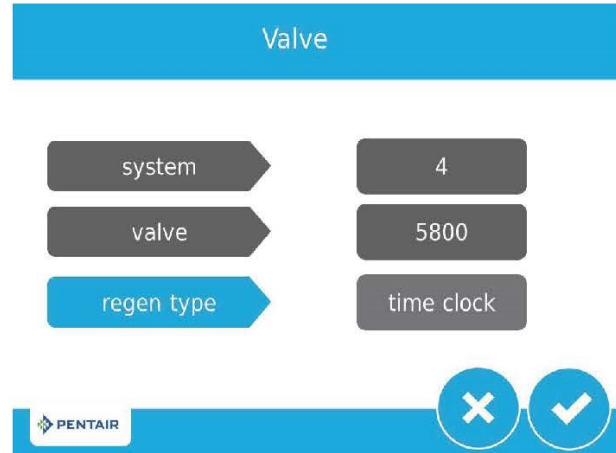

Figure 21 Valve Screen

- **system:** Displays the system type. Type 4 (single system) is currently the only available selection.
- **valve:** Contains settings to select the valve model installed with the control.
- **regen type:** Contains settings for the type of regeneration to use for the system. Regeneration types are described in detail below.

Regeneration Types

The XTR2 control supports several different Regeneration Types. The Regeneration Type defines the method of automatic regeneration for the system. Each type is explained below.

Time Clock

Triggers a regeneration on a timed interval. The control will initiate a regeneration cycle at the selected Regeneration Time when the number of days since the last regeneration equals the Day Override value. The Day Override can be set from 1 - 99 days as well as partial day intervals of 4, 8, 12, 16 and 20 hours.

Softener Immediate

Measures water usage and regenerates the system as soon as the calculated system capacity is depleted. The control calculates the system capacity by dividing the unit capacity by the feed water hardness. Softener Immediate systems do not use a reserve volume. The control will also start a regeneration cycle at the programmed regeneration time if a number of days equal to the Day Override pass before water usage depletes the calculated system capacity. The Day Override parameter default is OFF, and REGEN TIME will be grayed out unless the day override value has been modified.

CAUTION When setting the system for softener immediate regeneration, setting the capacity to a value lower than that of feed water hardness may cause the system to constantly regenerate. If this occurs, disconnect the motor from the control and correct the capacity and feed water hardness values in Master Settings. See "TROUBLESHOOTING" on page 17 for more information.

Softener Delayed

Measures water usage and regenerates the system at the selected Regeneration Time after the calculated system capacity is depleted. The control calculates the system capacity by dividing the unit capacity by the feed water hardness and subtracting the reserve.

MASTER SETTINGS PROGRAMMING

continued

The reserve should be set to ensure that the system delivers treated water between the time the system capacity is depleted and the actual regeneration time. Reserves can be set at a Fixed Volume, Fixed Percentage of capacity, a Variable Reserve based on the previous calendar day's water usage, or a Weekly Reserve based on the average water usage for the current day of the week. The default for the day override parameter is OFF, and the default reserve type is Weekly Reserve.

A Softener Delayed control will also start a regeneration cycle at the selected Regeneration Time if a number of days equal to the Day Override pass before water usage depletes the calculated system capacity.

If the regen type is changed from Softener Immediate to Softener Delayed (or vice-versa), all parameters within those types will be reset to factory default.

Filter Immediate

Regenerates the system immediately after the selected Volume Override value is depleted. A Filter Immediate control will also start a regeneration cycle at the selected Regeneration Time if a number of days equal to the Day Override pass before water usage depletes the calculated system capacity.

Filter Delayed

Regenerates the system at the selected Regeneration Time after the selected Volume Override value is depleted. A Filter Delayed control will also start a regeneration cycle at the selected Regeneration Time if a number of days equal to the Day Override pass before water usage depletes the calculated system capacity.

NOTE: If Filter Immediate or Filter Delayed are selected, Regenerant Flow selections are limited to Filter and Upflow Filter.

Regeneration Screen

From the main Master Settings screen (Figure 17) press the **regen** button to display the Regeneration screen.

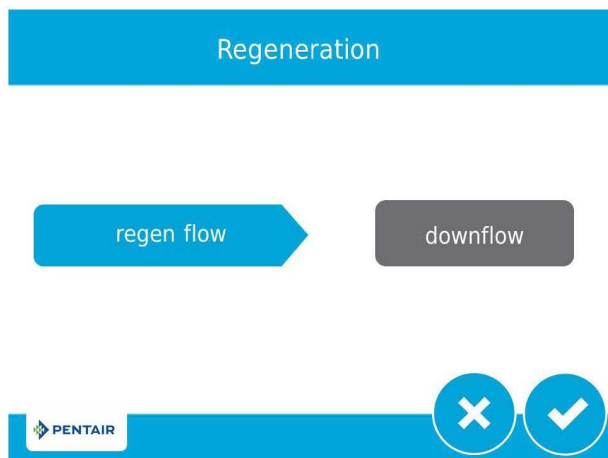

Figure 22 Regeneration Screen

CAUTION Adjusting Regeneration settings will turn any set relays off. Any required relays will need to be reprogrammed in the Relay Output screen.

- **regen flow:** Contains settings for the type of regenerant flow to be used in the valve. Changes to this setting affects the cycle steps displayed in the Regeneration Cycle Wheel on the Home screen. Regenerant flow cycle steps are described below. See TOUCHSCREEN CONTROL FEATURES for cycle step definitions.
 - **upflow:** Cycle steps are as follows: Draw, Backwash, Rinse, Refill
 - **downflow:** Cycle steps are as follows: Backwash, Draw, Rinse, Refill
 - **downflow 2X backwash:** Cycle steps are as follows: Backwash, Draw, Backwash, Rinse, Refill
 - **filter / upflow filter :** Cycle steps are as follows: Backwash, Rinse
 - **custom upflow / downflow:** Allows for up to 20 programmable cycle steps.
 - **variable refill:** Cycle steps are as follows: Refill, Pause, Draw, Backwash, Rinse. Variable refill calculates refill time based on salt dosage, media volume, and BLFC size.
 - **downflow no hard water bypass:** Cycle steps are as follows: Backwash, Draw, Rinse, Refill. This setting prevents hard water from flowing through the system during regeneration (5812 only).

Relay Output Screen

From the main Master Settings screen (Figure 17) press the **relay** button to display the Relay Outputs screen.

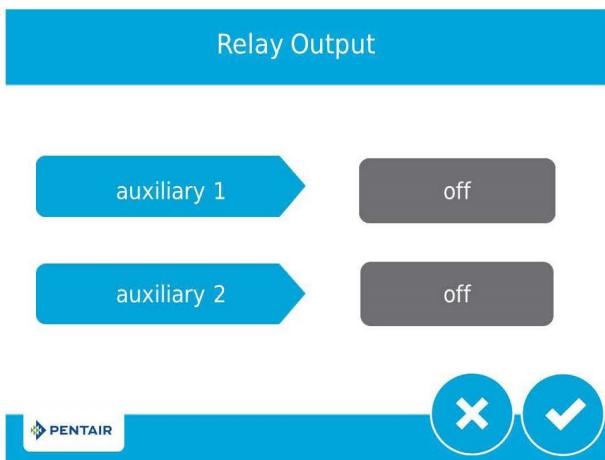

Figure 23 Relay Outputs Screen

- **auxiliary 1 / auxiliary 2:** Contains settings for programming up to two auxiliary relay outputs. There are three types of relays that can be programmed:
 - **Cycle Based:** The relay will turn on when the valve moves to the specified regeneration cycle steps. To program, select each cycle step button for which the relay should turn on.
 - **Time Based:** The relay will turn on and off at up to two specified start and end times.
 - **Volume Based:** The relay will turn on when the valve has treated a specified volume of water. Duration can be set for up to two hours.
 - **Alarm Based:** The relay will turn on when the specified alarm condition (or any alarm condition) is met. The relay will turn off when the alarm is cleared.

MASTER SETTINGS PROGRAMMING

continued

Meter Screen

From the main Master Settings screen [Figure 17] press the **meter** button to display the Meter screen.

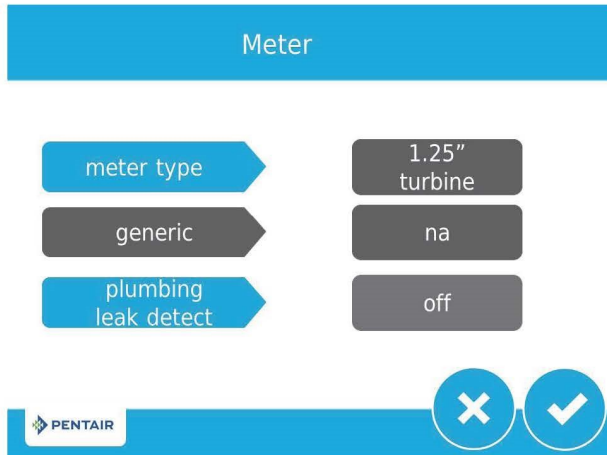

Figure 24 Meter Screen

- **meter type:** Contains settings for the type of meter installed with the system. The 5810/5812 valve uses an internal 1.25" turbine meter.
- **generic:** A generic option is available if the installed meter does not match any other selection. Requires setting the number of pulses per volume to ensure proper metering.
- **plumbing leak detect:** When active, triggers an alarm when continuous flow of .5 GPM or 1 LPM is detected by the flow meter over a 24 hour period.

Settings Review

From the main Master Settings screen [Figure 17] press the settings review button to display the Settings Review screens, which display a read-only summary of all programmed settings in the control.

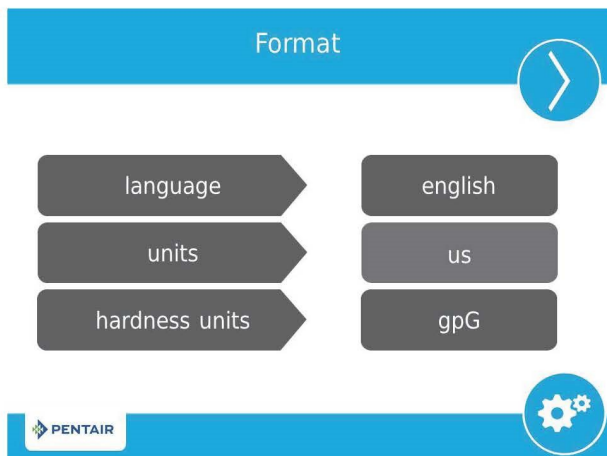



Figure 25 Format Settings Review Screen

Use the navigation arrows at the top of the screen to scroll through the parameters currently set in the control. The Settings Review screens are formatted similarly to the corresponding screen where each parameter was set. Press  to return to Master Settings.

Remote Regen Screen

From the secondary Master Settings screen [Figure 18] press the **remote regen** button to display the Remote Regen screen.

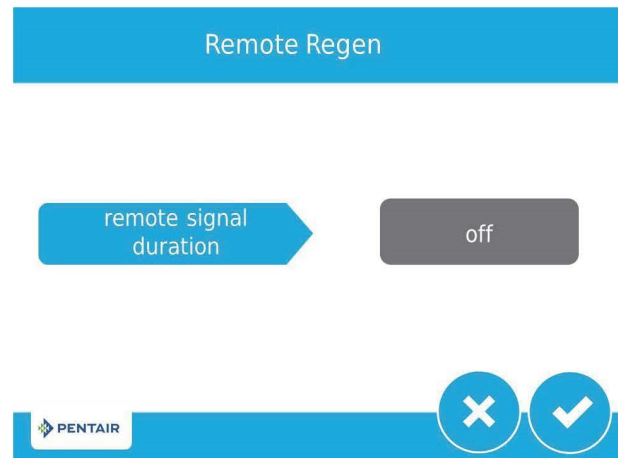

Figure 26 Remote Regen Screen



- **remote regen duration:** Contains settings for triggering a regeneration via a remote input. Select a value in seconds that the remote switch must be closed in order to trigger the regeneration.

Connect a remote switch (such as a differential pressure switch) to the remote start input terminals on the back of the XTR2 control board. See "WIRING DIAGRAM" on page 27. When the remote switch remains closed for the number of seconds specified in the Remote Regen screen, a regeneration will be triggered regardless of volume, capacity, or time remaining until the next scheduled regeneration.

MASTER SETTINGS PROGRAMMING

continued

Non-Factory Settings

After all parameters in Master Programming have been set, these settings can be saved to a custom profile by pressing  on the main Master Settings screen (see Figure 17 Master Settings Screen). After pressing , the Non-Factory Settings screen appears.

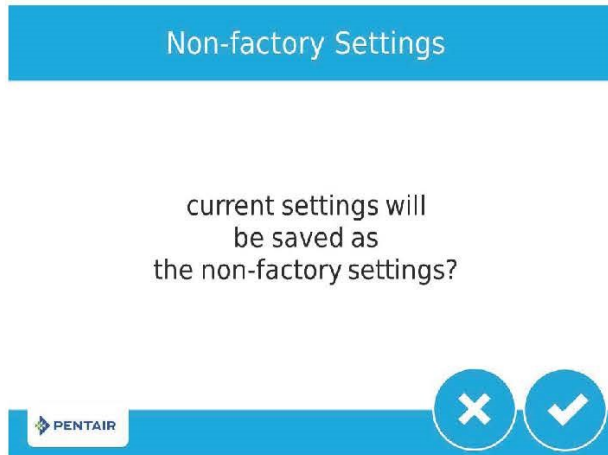



Figure 27 Non-Factory Settings Screen

Press  to save all programmed Master Settings parameters to non-factory settings. At any point, the control can be reset to these saved custom settings (see "MASTER RESET" on page 16). By performing a custom reset, any setting that is subsequently programmed without saving to non-factory settings will be reset to the previously saved non-factory settings in the control.

Diagnostics

The control records and displays a variety of diagnostic data to assist with troubleshooting performance issues and fine-tuning system efficiency. Press the **Diagnostics** button  from the Master Settings or Home screens to view the Diagnostic screen.

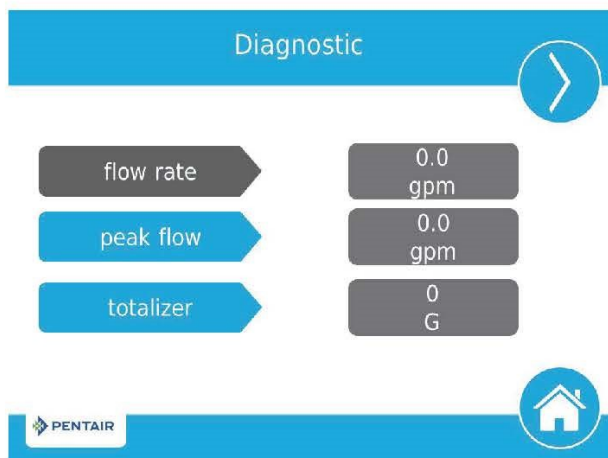



Figure 28 Diagnostic Screen

- Press the screen navigation arrows at the upper-right and left of the screen to view each diagnostic parameter.
- Press the **Home** button  to return to the Home screen.

NOTE: If a regeneration occurs while in the Diagnostic screen, the unit will return to the main screen.

Parameter	Description
Flow Rate	Displays the current flow rate.
Peak Flow	Displays maximum flow rate of water along with date and time of occurrence, since last reset.
Totalizer	Displays total volume of water used since last reset.
Last Regen	Displays when last regeneration occurred.
Reserve	Displays the reserve volume based on the reserve type selected under master settings. *This parameter is only available for meter delayed regeneration type.
Software Ver	Displays the software version installed on the controller.
No of Regens	Displays how many manually and system initiated regenerations the system has gone through since last reset.
Regen Interval	Displays the average length of time between regenerations based on the past four regenerations.
Daily Usage	Displays average water usage for each day of the week based on the usage on that day for the past six weeks.
Usage Since Regen	Displays water usage since last regeneration.
Last Setting Change	Displays the date and time of the last update to Master Settings.

NOTE: Only Peak Flow and Totalizer can be changed - they can be reset to zero.

NOTE: Totalizer has a maximum value of 99,999,999. If this number is reached, the Totalizer must be reset to zero to continue tracking this value.

MASTER SETTINGS REFERENCE CHART

CAUTION Before entering Master Settings, please contact your local professional water dealer.

Master Settings Options			
Screen Name	Parameters	Values	Notes
Format	Language	English French German Italian Spanish	Changes the language to display screen text and button labels in the control (available with international version of control only).
	Units	U.S. Metric	Changes system units and values across all parameters in the control. All programmed units and values should be recalculated after adjusting this setting.
	Hardness Units	Grains per gallon mg/L or ppm German degrees French degrees English degrees	Changes hardness units used in displaying hardness parameters and calculating system capacity and editing exchange capacity and hardness settings.
Assistance Name	Free-form text	A - Z and space	Name of service provider to display when viewing the Assistance screen. 20 character limit.
Assistance Phone	Free-form text	0 - 9 and space	Phone number of service provider to display when viewing the Assistance screen. 20 character limit.
Assistance Interval	Month Based Regen Based	1 - 60 1 - 2000 Off	Set to automatically display the Assistance screen after a certain number of months or regenerations.
Valve	System	4	System 4 (single system) is currently the only available selection.
	Valve	5810 5812	Select the type of valve to be installed.
	Regen. Type	Time Clock Softener Immediate Softener Delayed Filter Immediate Filter Delayed	Regeneration Types are described in detail on page 11. Additional Valve screen parameters are dependent upon selected Regeneration Type. Not all parameters will be displayed. Softener Delayed regeneration type has four reserve options (Fixed %, Fixed Volume, Variable Reserve, Weekly Reserve). The control will display additional configuration options depending on the selected reserve type.
	Capacity	1 - 99 999 999 grains / grams / degrees	Only required on metered systems to calculate treated water capacity and reserve. Represents total system capacity between regenerations.
	Hardness	1 - 199 grains/gallon 1 - 1 999 mg/liter x - x degrees	Only required on metered systems to calculate treated water capacity and reserve. Represents hardness of untreated water.
	Reserve	Fixed % Fixed Volume Weekly Reserve Variable Reserve	Only available when Meter Delayed regeneration type is selected. Selecting Fixed % or Fixed Volume will display additional configuration options. Weekly Reserve is calculated based on average day of week's water usage. Variable Reserve is calculated based on previous day's water usage.
	Day Override	1 - 99 days 4, 8, 12, 16, 20 hours	Available to be programmed for all Regeneration Types.
	Regen Time	12 / 24 hour clock	Required for Time Clock and delayed Regeneration Types. Set for immediate regeneration types only when a Day Override is also set.
	Volume Override	1 - 99 999 999 gallons / liters	Only displayed when Regeneration Type is Filter Immediate or Filter Delayed.
Regeneration	Regen. Flow	Upflow Downflow Downflow 2x Backwash Filter Upflow Filter Custom Upflow Custom Downflow Variable Refill Downflow No Hard Water Bypass	Cycle steps on the Home screen and during regeneration will change to reflect the cycle steps and order in the selected Regenerant Flow. Additional Regeneration screen parameters are dependent upon selected Regenerant Flow. Not all parameters will be displayed. Custom Upflow and Downflow allows for up to 20 programmable cycle steps. Variable Refill calculates refill time based on Salt Dosage, Media Volume, and BLFC Size. Time per cycle step can be programmed for all other Regenerant Flow options. Downflow No Hard Water Bypass is available for 5812 only.
Relay Outputs	Aux 1/Aux 2	Cycle Based Time Based Volume Based Alarm Based Off	For Cycle Based relays, select the cycle steps on which the relays will turn on. For Time Based relays, two start/end times will need to be selected for each relay. Relay times are based on total regeneration cycle time. Volume Based relays can be programmed from zero gallons/liters to the full system capacity. Duration can be set from zero seconds to two hours. Volume Based option is not available when Regeneration Type is set to Time Clock. Alarm Based relays will turn on when an alarm condition is met, and will turn off when the alarm is cleared.
Meter	Meter Type	.75 inch Paddle 1.00 inch Paddle 1.25 inch Turbine 1.50 inch Paddle 1.50 inch Turbine 2.00 inch Paddle 3.00 inch Paddle Generic	Select the type of meter installed with the system. A Generic option is available if the installed meter does not match any other selection. Selecting the Generic meter type requires setting the number of pulses per gallon or liter to ensure proper metering.
	Generic	1 - 999.9 / 1 - 1500 pulses per gallon / liter	Only available when Generic meter type is selected.
Remote Regen	Remote Regen	1 - 255 seconds Off	Select a value in seconds that the remote switch must be closed in order to trigger the regeneration.

NOTE: Some items may not be shown depending on control configuration. The control will discard any changes and exit Master Settings if any button is not pressed for five minutes.

MASTER RESET

Press the  button while in the Master Settings main screen (Figure 17) to display the Reset screen.

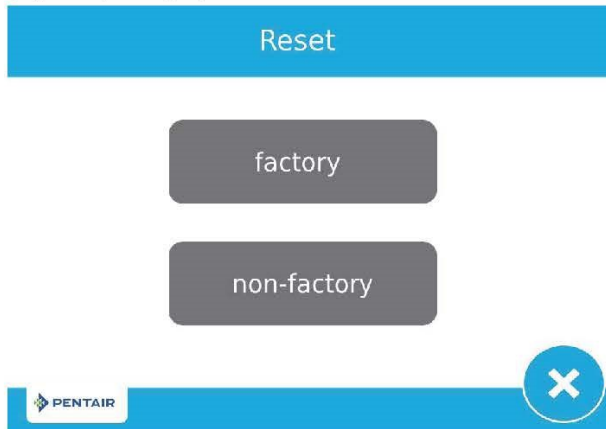





Figure 29 Reset Screen

Press the **factory** button to reset all control parameters to their factory defaults, or press the **non-factory** button to reset control parameters to previously saved custom settings (see "NON-FACTORY SETTINGS" on page 14). A warning screen appears before parameters are reset. Press  to confirm the reset or press  to return to Master Settings.

CONTROL OPERATION

Control Operation During Regeneration

During regeneration, the Regeneration Cycle Wheel shows the regeneration step the valve is advancing to, or has reached, and the time remaining in that step. Once all regeneration steps are complete the valve returns to treatment position and resumes normal operation. The time remaining in regeneration will be displayed on the home screen in hours and minutes.

Pressing the  button during a regeneration cycle immediately advances the valve to the next cycle step position and resumes normal step timing. The  button is only shown when the valve is in position and the motor has stopped.

Control Operation During Programming

The control can only be programmed with the valve in treatment. While being programmed the control continues to operate normally, monitoring water usage and keeping all displays up to date. Control programming is stored in memory permanently until reset.

Control Operation During a Power Failure

The XTR2 includes internal power backup. In the event of power failure, the control shifts into a power-saving mode. The control stops monitoring water usage. The display and motor shut down, but it continues to keep track of the time and day for a minimum of eight hours.

The system configuration settings are stored in a non-volatile memory and are stored indefinitely with or without power. After a long power outage, the Time of Day button may flash indicating it needs to be reset. Press the button to stop the Time of Day from flashing and reset time if needed.

If power fails while the unit is in regeneration, the control will save the current valve position before it shuts down. When power is restored, the control will resume the regeneration cycle from the point where power failed. If power remains off for more than eight hours, upon power restoration the regeneration is canceled and the piston returns to service.

CAUTION If power fails during a regeneration cycle, the valve will remain in its current position until power is restored. The valve system should include all required safety components to prevent overflows resulting from a power failure during regeneration.

The control will not start a new regeneration cycle without power. If the valve misses a scheduled regeneration due to a power failure, it will queue a regeneration. Once power is restored, the control will initiate a regeneration cycle the next time that the Time of Day equals the programmed regeneration time. Typically, this means that the valve will regenerate one day after it was originally scheduled. If the treated water output is important and power interruptions are expected, the system should be set up with a sufficient reserve capacity to compensate for regeneration delays.



Remote Lockout

If a remote switch is installed, the control will not allow the system to go into regeneration until the regeneration lockout input signal to the control is cleared. This requires opening the contact closure to clear the lockout condition. The recommended gauge wire is 20 with a maximum length of 500 feet. See "WIRING DIAGRAM" on page 30.

Sleep Mode

The control will go into sleep mode if no button is pressed after five minutes. All other control functions will continue to operate. The display will wake from sleep mode when any part of the display is touched.

ALARMS AND ERRORS

If an error in valve or control function occurs, an alarm will sound and the Home screen will display the Error Alert button  and the Alarm button .

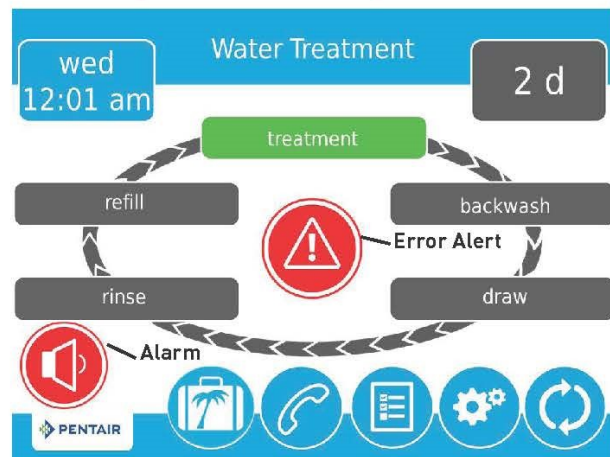

Figure 30 Alarm and Error Alert

- Press the **Alarm** button to mute the alarm.
- Press the **Error Alert** button to view information about the error.

If the display is in sleep mode when an error occurs, the screen will turn on for five minutes. The error will beep for one second per minute until the error is cleared. If the error is not cleared after five minutes, the screen will switch to power saving mode and display the Error Alert button as a screen saver.

See TROUBLESHOOTING for more information about error conditions.

TROUBLESHOOTING

Problem	Cause	Correction
Valve constantly regenerates	Error in programming has caused a regeneration loop condition in the control.	Disconnect the motor from the control circuit board (see "WIRING DIAGRAM" on page 30 for location on circuit board). A Motor Stall error will occur, allowing access to Master Settings. Navigate to the Valve screen and check Regen Type settings. Ensure that the value for Capacity is larger than the value for Hardness, and save settings. If the error continues to occur, unplug the unit, put it into bypass and contact technical support.

Error Alerts

NOTE: An Error Alert appears on the Home screen if an error condition is detected. Press the Error Alert button  to view the error message.

NOTE: Most error alerts are cleared at regeneration. If the error persists following a regeneration attempt the appropriate reset and recovery procedure below or contact technical support.

Error Screen Display	Cause	Reset and Recovery
Motor Stall No changes detected in the optical sensor for 6 seconds	No state changes in the optical sensor are detected for six seconds.	Unplug the unit and plug back in. Allow the control to attempt to find position again. Verify the optical sensor is in place with the wires connected to the circuit board. Verify the motor and drive train components are in good condition and assembled properly. Check the valve and verify that the piston travels freely. Replace/reassemble the various components as necessary. Plug the unit back in and observe its behavior. If the error reoccurs, unplug the unit, put it into bypass and contact technical support.
Motor Run-On Undesired change detected in the optical sensor	An undesired optical sensor state change occurred.	Non-critical error. Extra optical sensor pulse detected. Press the Regeneration button to advance motor to clear error.
Plumbing Leak	The flow meter has reported continuous flow for more than 24 hours.	Error will clear when flow to meter drops below 0.5 GPM or 1 LPM. If continuous flow is expected, turn plumbing leak detection off in Master Settings.
Valve Position Valve took over a minute to find cycle step	Valve has failed to find position in one minute.	Unplug the unit and plug it back in. If error continues, call technical support. Check the valve and verify that the piston travels freely. Replace/reassemble the various components as necessary.
Reset Error Probable Mechanical Failure	The valve has reset at least five times in a short amount of time.	Attempt to perform a manual regeneration. If error continues, call technical support.

WIRING DIAGRAM

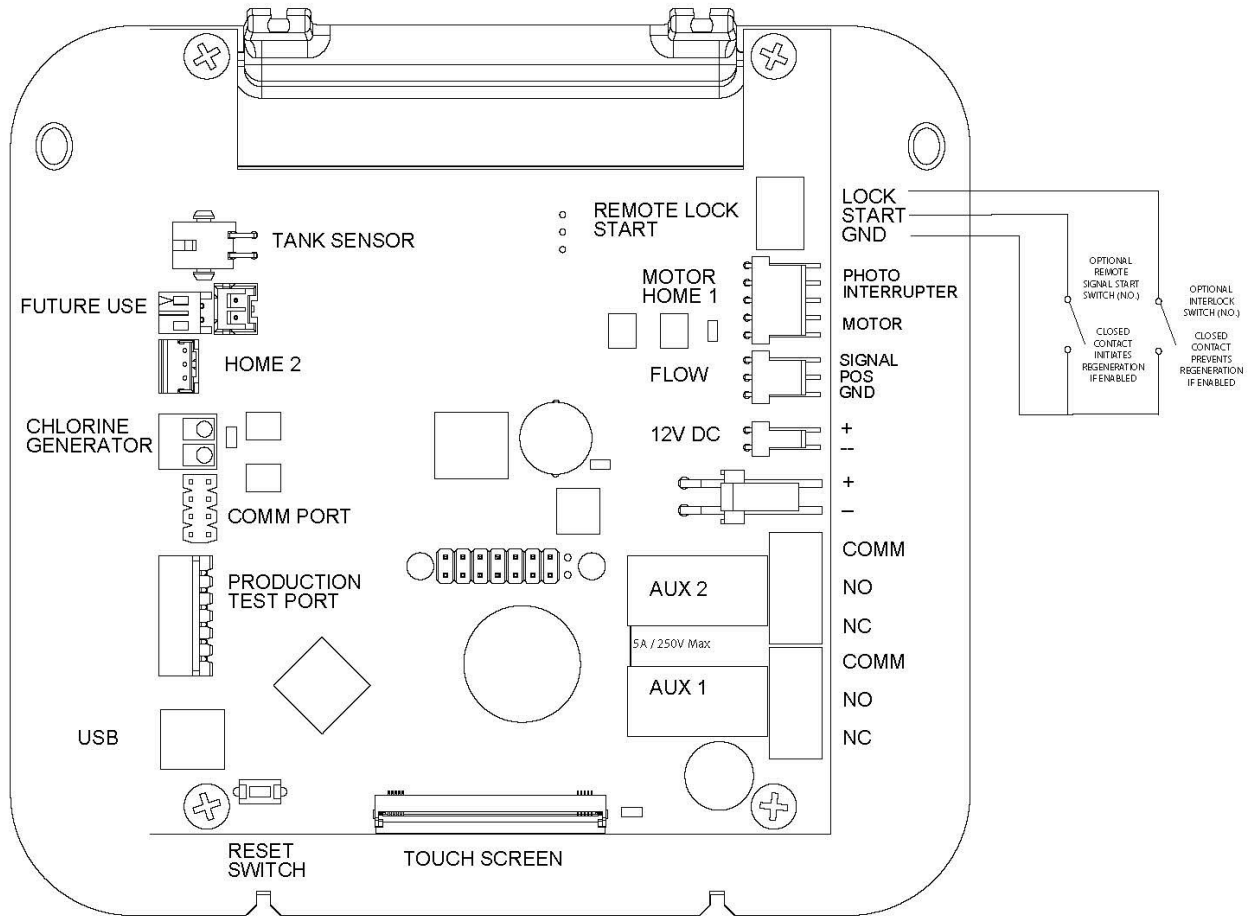

NOTE: The reset switch discharges the super capacitor when power is removed from the control. The super capacitor retains the current time of day in the event of a power failure. Pressing the reset switch on the circuit board while power is applied to the control will have no effect on the control or stored settings.

System Control & Operation

Your Crusader Water Quality Management System incorporates a highly sophisticated microprocessor control system, making it as efficient and reliable as possible. All system settings are pre-programmed at the factory and then carefully calibrated by your qualified installer for your specific application and area.

Your Crusader Water Quality Management System incorporates flash EEPROM memory and an innovative power backup system, which means that your system programming should never have to be reset, even in the event of an extended power outage. Your system can also be upgraded with the latest software and hardware revisions as they become available. Visit your local authorized dealer for more information.

Normal Operating Mode

In **normal operating mode**, the display shows the time of day, capacity remaining, and the system status. Your system continuously monitors the flow meter and makes decisions on when and how to clean based on its programming profile and observations of your water usage habits.

Flow meter

In **service mode**, the display will show the time of day and remaining capacity. The remaining capacity counts backwards in gallons as water is used. The flow display indicator can be used to determine if the flow meter is working by opening a faucet downstream of the system and observing the gallons count down as well as the flow glyph.

Power-Failure Handling

In the event of a power failure, your system's integrated Snapshot memory system will retain all programmed data indefinitely. The system will maintain the correct time of day during a period of several hours. In the case of a prolonged power failure, the time of day might not be maintained; if this happens, the time of day indicator will, when the power supply is re-established, be *flashing*, indicating that the time of day needs to be set. All other programming is unaffected.

Critical Software/Hardware failure

After a critical software or hardware failure, the **Error Information Icon** could illuminate solid or blinking. Call your local service provider for help.

Cleaning/Regeneration mode

Cycle times will vary depending on your water usage habits, the system operational history, pre-programmed settings and other environmental factors. In **regeneration mode** the display shows the current cleaning cycle description and the remaining time for that cycle to execute. The cleaning sequence is as follows:-

Tank Fill	Your system calculates the exact amount of brine solution required to properly clean itself, based on pre-programmed settings, operational history, your water usage habits and the age of the system. Your system is online and in service at this time.
Percolation	Your system remains online and in service while the water and salt slowly mix together to create a perfectly saturated sodium or potassium brine solution
Backwash	Your system rapidly discharges water upwards through the media bed and to the drain. This backwash step ensures that trapped sediment and broken media particles are flushed out of the system to minimize pressure loss and channelling.
Brine Draw	Your system will extract brine water from the brine tank and apply it to the ion exchange media in the tank.
Slow Rinse	Your system will continue injecting brine into the media tank. Once the brine supply is exhausted, your system will begin slowly rinsing contaminants through the media bed and out of tank to drain.
Rapid Rinse	A high velocity stream of water is directed downwards through the multimedia bed to compact each of the media layers, flush hard water from the tank and prepare for returning itself to service.
Return to Service	The system slowly drives the operating piston to the home position and gracefully brings itself back online, ready to work hard for you.

Your system will periodically perform an antibacterial deep cleaning. This cleaning cycle will occur after a designated period of time (we recommend at least every once a week). This cleaning cycle will inject ProGuard into your system and possibly even use salt to clean itself, depending on your water usage. If you haven't used any water during that interval, the system will not use any salt during the antibacterial cleaning cycle.

Understanding how your system operates

Every day, thousands of billions of tons of water evaporate from the earth's surface.

As the heat of the sun evaporates the water and draws it from the earth's surface into the atmosphere, many impurities are left behind. The water vapor eventually cools to form clouds and then falls back to earth as precipitation.

On its way from the clouds to your faucet, soft rain water dissolves and absorbs a part of almost everything it touches.

Falling rain cleans the air as it falls. Unfortunately the impurities that were removed from the air have not left; they have just been relocated through the water onto the ground. These gases and other airborne contaminants can cause undesirable tastes, colors and odors in water.

Rain falls onto the ground, collecting sediments like rust, sand and even algae. The water eventually finds its way to a surface water supply or percolates downward and collects in an aquifer. As it percolates through the earth, the water can absorb hardness minerals, iron, heavy metals, radioactivity, organic contaminants, and many other complex elements and compounds.

Water can also collect numerous harmful man-made chemical impurities during this cycle. These synthetic chemicals are generally odorless, colorless, and tasteless; and can sometimes be life-threatening. The statement: "my parents drank this water for 50 years and it never hurt them", is no longer a valid excuse to not be concerned with water quality. There has been a massive global increase in harmful chemical waste over the last 50 years.

The scientific and medical community has not had the time or budget to study the long-term health effects of the more than 70,000 harmful chemicals that can be found in use today.

Approximately 1,000 new synthetic chemical compounds are entering the industrial marketplace each and every year. Precipitation falls upon commercial and municipal dumpsites, toxic waste sites, industrial refuse depots, military test sites, leach fields, mining operations, farmer's fields etc... Where it dissolves minute amounts of the toxic chemicals present and carries them along.

The United States Government estimated in 1986 that close to two percent of the nation's ground water supplies were moderately polluted by sources such as hazardous waste dumps and leaking landfills.

Industrial wastewater is also a major source of water contamination. Chemicals that are considered generally acceptable in controlled amounts may react with other elements and/or chemicals to form new compounds that could be highly carcinogenic.

Chlorine is one of the best-publicized examples; it reacts with organic matter in water and forms deadly trihalomethanes.

Hard water is one of the major threats facing the American home in the 21st century. Hard water can coat you, your family, your home and your appliances with thousands of pounds of inorganic mineral rock-scale each and every year. Hard water slowly destroys everything it touches; left untreated, hard water costs you money, ruins your lifestyle and can even lower the value of your home.

No one needs to tell you that you're living with Hard Water though. Soap doesn't lather easily, glasses are cloudy after washing, a ring forms around the bathtub, faucets and shower heads are crusty, laundering results are poor and there are many other easily recognized signs.

There are several degrees of water hardness. Even moderately hard water can seriously damage the plumbing system in your home and, in time, cause inconvenient and expensive problems.

Hard water is a poor cleaner because it is loaded with a variety of impurities. These dissolved impurities react with certain chemicals found in soap to form a gummy, insoluble curd that clings stubbornly to everything it touches. The ring around your bathtub is curd. That same curd causes your hair to become dull and hard to manage.

Soap curd clogs skin pores and prevents your natural oils from properly moisturizing your skin. This dryness causes itching and also can aggravate skin conditions like psoriasis, eczema and acne.

Soap curd is especially noticeable by the scummy film it forms on dishes, glassware, walls and floors. Hardness and other dissolved solids combine to form the residue you see as spots on glasses, crockery, cutlery and shower enclosures.

How water hardness is measured

Water hardness is measured in imperial Grains per Gallon (gpg). A grain, is the weight of an average dry grain of wheat, approximately 1/7000th of a pound.

Soft Water	0 - 0.5 gpg
Slightly Hard Water	.5 - 3.5 gpg
Moderately Hard Water	3.5 - 7 gpg
Very Hard Water	7 - 10.5 gpg
Extremely Hard Water	10.5 gpg and greater

Water Softening Process

The smallest units that make up chemical compounds and still retain the properties of those compounds are called molecules. Molecules are made up of atoms or groups of atoms. Electrically charged atoms are called ions. The charge of a single ion can be either positive or negative - Ions of metals and minerals are usually positively charged and called cations. Ions such as chlorine, nitrate, phosphate, fluoride and sulfates are negatively charged and called anions.

Certain insoluble materials are made up of large ions forming a skeletal structure containing oppositely charged ions. These ions can be exchanged with other similar ions in an ion exchange.

The first commercial application of ion exchange was water softening in 1905. Since then, ion exchange has been the most reliable & cost-effective method of softening and conditioning water in homes and industry.

The Softening of water by ion exchange relies on the replacement of the calcium and magnesium ions in the water by an equivalent number of sodium ions.

The Softening process may be illustrated by the following equation:-

$R_2.Na +$	$Ca(HCO_3)_2 =$	$R_2 . Ca +$	$2NaHCO_3$
Sodium Ion Exchange Resin	Calcium Bicarbonate in water	Calcium Ion Exchange Resin	Sodium Bicarbonate in Water

Obviously, the system can only exchange a certain amount of hardness and other contaminants before becoming exhausted. This is referred to as the capacity of the resin. The capacity of the resin is referred to as grains of calcium carbonate hardness removed per cubic foot of resin or Milliequivalents per liter. When the capacity has been exhausted, the resin needs to be regenerated with a solution of sodium chloride (brine) as follows:

$R_2.Ca +$	$2NaCl =$	$2 R.Na +$	$CaCl_2$
Calcium Ion Exchange Resin	Sodium Chloride Brine	Sodium Ion Exchange Resin	Calcium Chloride Waste

Ion exchange resins used in your Crusader Water Quality Management System are made without harmful toxic solvents. This media is designed to be physically and chemically strong while producing water that feels good, tastes great and works hard for you.



Your Crusader Water Quality Management System can be regenerated with Potassium Chloride salt if desired.

What is Hard Water Costing You?

Items affected by hard water	Average Family Cost		Average Family Savings		Average % Saved
	Per Year	Per Month	Per Year	Per Month	
Plumbing and Appliances Replacement and repairs of pipes, faucets, washer, dishwasher, and water heater, etc. <i>Water Quality Research Council Study</i>	\$120.00	\$10.00	\$90.00	\$7.50	75%
Cooking and coffee Tea, sugar, canning, etc. <i>National Restaurant Association</i>	\$118.56	\$9.88	\$22.44	\$1.87	25%
Personal Care Items Slips, lingerie, etc. <i>American Laundry Institute</i>	\$60.84	\$5.07	\$18.24	\$1.52	30%
Clothing and linens Washable items such as towels and linens <i>American Laundry Institute</i>	\$600.00	\$50.00	\$175.00	\$15.00	30%
Energy Consumption Heat loss due to scale <i>University of New Mexico and WQA Studies</i>	\$320.00	\$26.67	\$64.44	\$5.37	20%
Soaps and Cleaning Aids Laundry, cleaning, dishwashing, bathing, skin-care, shaving, shampoo etc... <i>Orange County Consumer Survey *10 or more hours of cleaning a month</i>	\$1,032.00	\$86.00	\$774.00	\$64.50	75%

What Could Soft Water Be Saving You?

TOTAL COSTS AND SAVINGS		
	Hard Water Cost	Soft Water Savings
Total Per Day	\$6.25	\$3.19
Total Per Month	\$187.62	\$95.76
Total Per Year	\$2,251.44	\$1,149.12
Total Over 10 Years	\$22,514.40	\$11,491.20

The figures above are National Average Figures based upon an average family of 4 persons with an average water hardness of 10 grains per gallon

THE CRIMES OF HARD WATER, METALS & CHLORINE

Increased Water Heating Costs

Damaged Clothing

Excessive Soap Consumption

Pipe Scaling

Faucet and Fixture Damage

Skin Problems

Unpalatable Food

Undesirable Tastes and Odors

Premature Appliance Failure

Unsatisfactory Laundry Results

Unpleasant Tastes & Odors in Water

Staining on Faucets, Fixtures & Appliances

System Troubleshooting Guidelines

These troubleshooting guidelines are not intended to be all-inclusive or to substitute the expert diagnosis of your local Certified Water Professional.

Hard (untreated) water to service

Cause	Solution
Open or defective bypass	Close or verify bypass
Loss of media	Refer to problem "Loss of media"
Unit fails to regenerate	Refer to problem "System fails to clean"
Valve fails to draw brine	Refer to problem "System fails to draw brine"
Decreasing exchange capacity of resin	Clean or replace resin bed
No salt in brine tank	Add salt
Leak at riser tube	Verify that riser tube is seated correctly and is not damaged by heat or high water pressure
ProGuard supply exhausted	Refill ProGuard feeder

System fails to regenerate

Cause	Solution
Faulty electrical supply	Verify electrical service – Confirm unswitched power outlet
Obstructed flow meter	Clean and/or replace flow meter
Damaged PCB	Replace PCB
Damaged drive motor	Replace drive motor

Loss of Water Pressure

Cause	Solution
Mineral or iron build-up in resin tank	Clean resin bed and control valve; increase regeneration frequency. Increase ProGuard dosage rate
Plugged lower and/or upper distributor	Verify that distributors are free of debris
Crushed lower and/or upper distributor	Replace distributor/s - Check for adequate temperature/pressure protection
Resin damaged due to natural attrition or chlorine/chloramine oxidation	Replace Resin

System runs continually down the drain

Cause	Solution
Piston stuck in brine/rinse or back-wash position	Inspect drivetrain and perform remedial action
Damaged Seals/Spacers	Inspect Seals/Spacers and perform remedial action
Damaged Piston	Inspect drivetrain and perform remedial action

Loss of media through drain line

Cause	Solution
Lower and/or upper distributor damaged	Replace distributor(s)
Leak between riser tube and upper distributor	Verify that riser tube is seated correctly and is not cracked
Heat and/or Pressure Damage	Inspect pressure regulating valve and hot water backup protection devices. Perform appropriate remedial action.

System Fails to Draw Brine—Not Using any Salt

Cause	Solution
Low operating pressure	Verify operating pressure; must exceed 30 psi dynamic
Plugged injector	Clean injector
Plugged injector filter	Clean injector filter
Piston/stuck in incorrect position	Inspect drivetrain and perform remedial action
Restricted/Obstructed drain line	Check drain line for kinks, restrictions or obstructions
Restricted/Obstructed brine line	Check brine line for kinks, restrictions or obstructions
Leak in brine line	Verify brine line and connections for air leakage
Insufficient water in brine tank	Refer to problem "System fails to refill brine tank"

Excessive water in brine tank

Cause	Solution
System fails to draw brine	Refer to problem "System fails to draw brine"
Improper brine refill time setting	Verify that brine refill time corresponds to the proper salt level and amount of ion exchange resin and other media
Missing brine refill flow control	Verify that flow control is installed and properly sized
Leak from valve to brine tank	Clean or replace Brine Valve
Brine Valve damaged	Replace Brine Valve

System uses too much salt

Cause	Solution
Excessive water in brine tank	Refer to problem "Excessive water in brine tank"
System cleaning frequently	Check household for excessive or unexpected water usage — leaky toilet fill valves, T&P Relief drainage, Reverse Osmosis processors, humidifiers, plumbing leaks etc...

Salty water to service

Cause	Solution
Excessive water in brine tank	Refer to problem "Excessive water in brine tank"
Injector undersized	Verify injector selection
Injector fouled	Remove and clean injector
Improper brine/slow rinse time setting	Verify that brine/slow rinse time corresponds to the proper salt level and amount of resin
Improper fast rinse time setting	Verify that fast rinse time corresponds to the proper salt level and amount of resin

System fails to refill brine tank

Cause	Solution
Improper brine refill time setting	Verify that refill time corresponds to salt level and amount of resin
Plugged refill flow control	Clean flow control

5800 Bypass Assembly

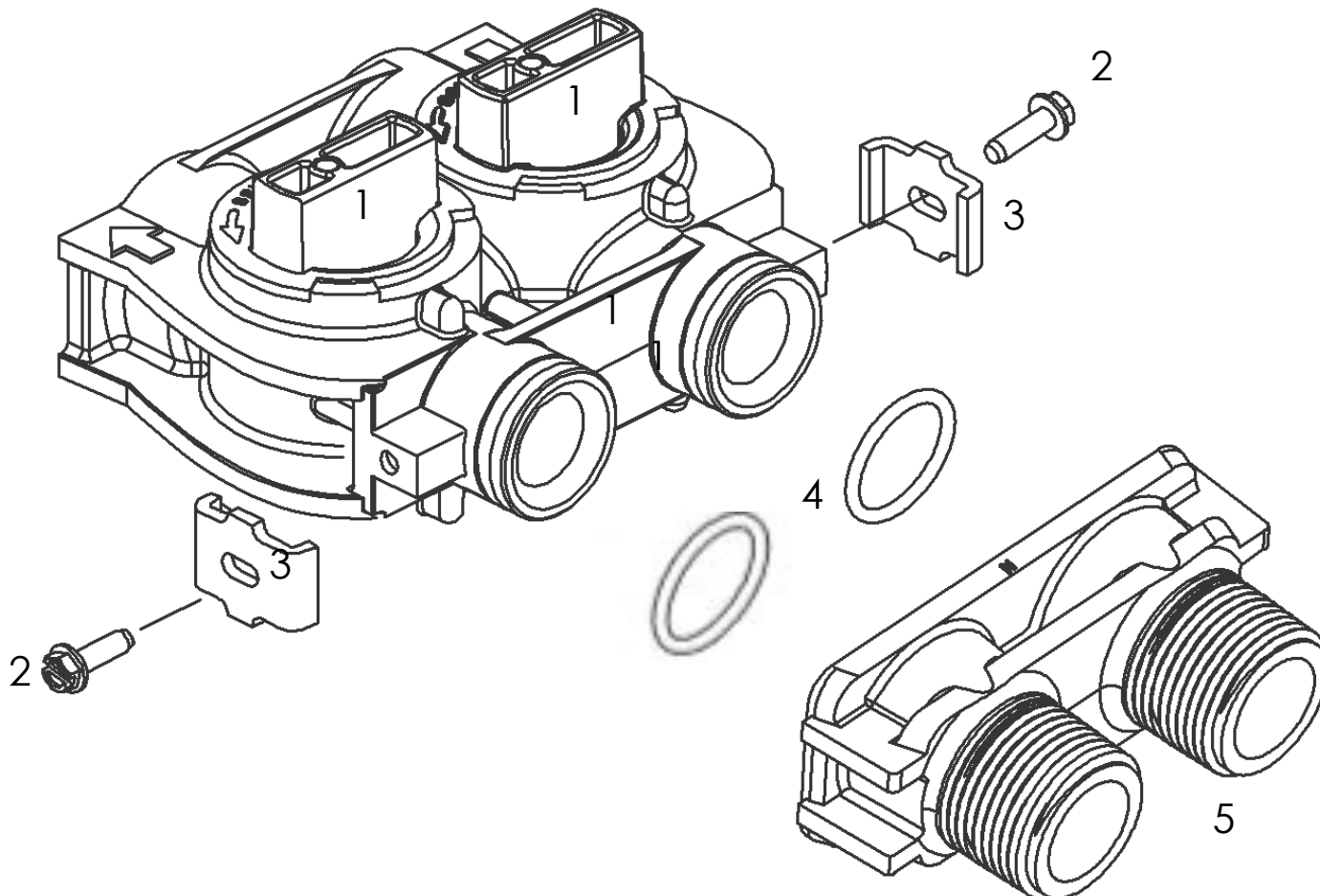

Item #	Qty	Part #	Description
1	1	60049	Composite Bypass Assembly
2	2	13314	Screw, Slot Ind Hex, 8-18 x 0.60
3	2	13255	Stainless Steel Mounting Clip
4	2	13305	O-Ring—119
5	2	18706	1" Composite NPT Yoke



To bypass the system, turn bypass knobs to bypass position. When returning to service, put the inlet into service before the outlet.



The System must be **BYPASSED, DEPRESSURIZED** and **DE-ENERGIZED** before disassembling or performing mechanical repairs



Disassembly, Repair/Replacement/ Reassembly should only be performed by properly trained service personnel

5810 Bypass Assembly

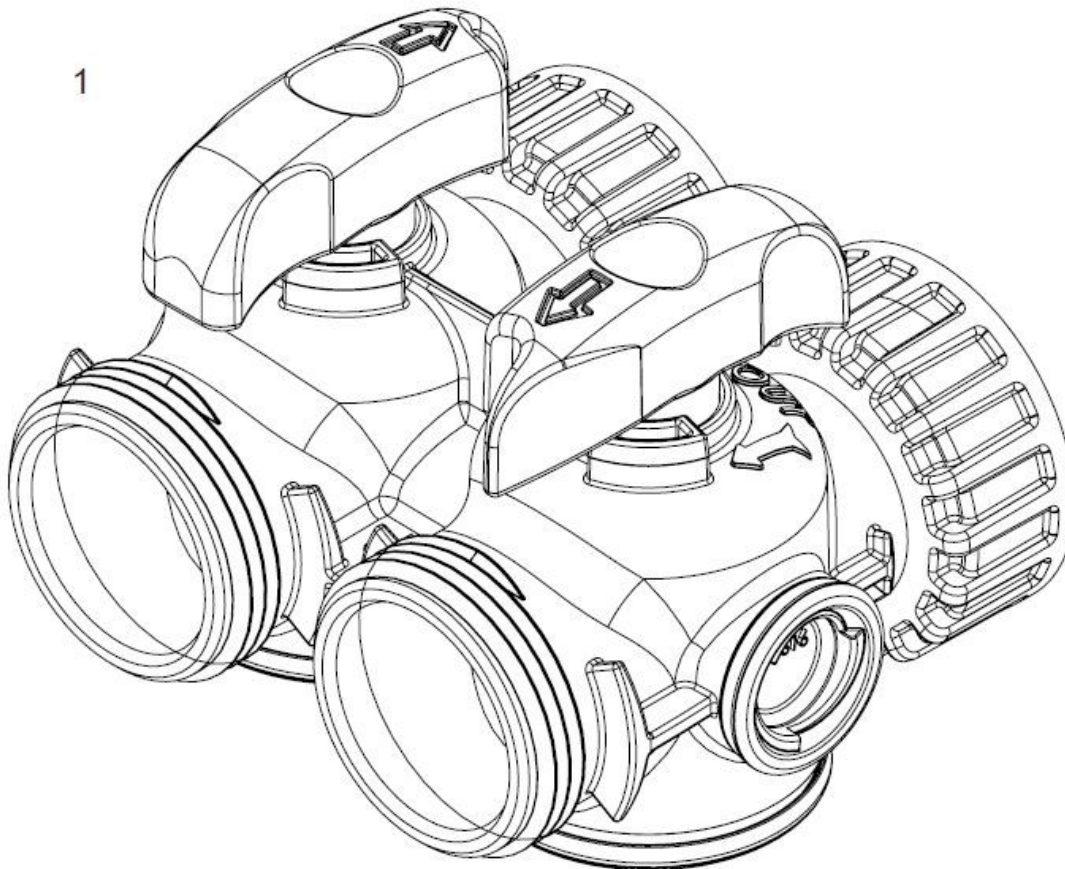

Item #	Qty	Part #	Description
1	1	43644	Composite Bypass Assembly 5810/5812
	OPTIONAL	61991-01	Connector Assembly, 1" NPT
	OPTIONAL	61991-03	Connector Assembly, 1-1/4" NPT
	OPTIONAL	61991-05	Connector Assembly, 3/4" - 1" Sweat
	OPTIONAL	61992	Elbow Assembly



To bypass the system, turn bypass knobs to bypass position. When returning to service, put the inlet into service before the outlet.



The System must be **BYPASSED, DEPRESSURIZED** and **DE-ENERGIZED** before disassembling or performing mechanical repairs



Disassembly, Repair/Replacement/ Reassembly should only be performed by properly trained service personnel

Powerhead Assembly SXTi

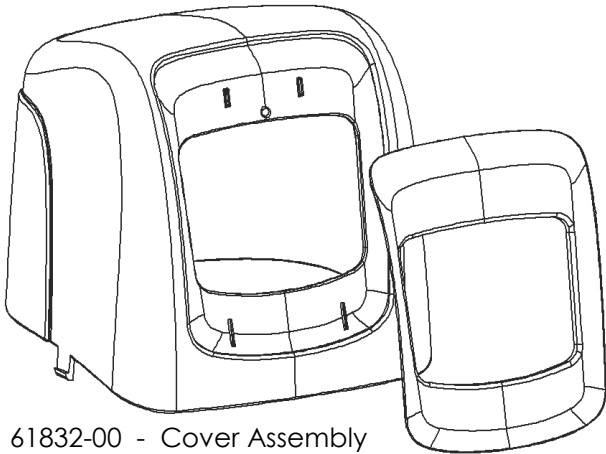

61832-00 - Cover Assembly

61835 - Motor Assembly

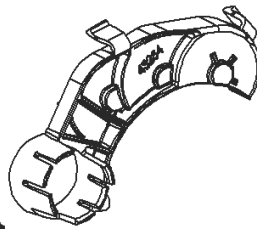
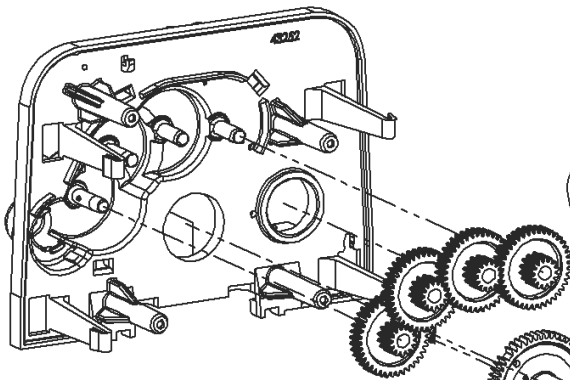
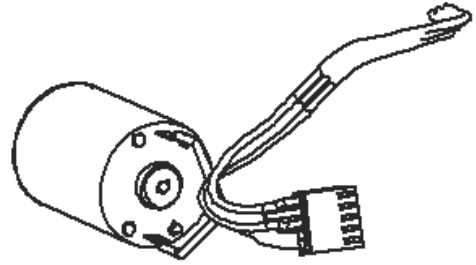

61836 - Panel Gear Assembly, Downflow/ Upflow

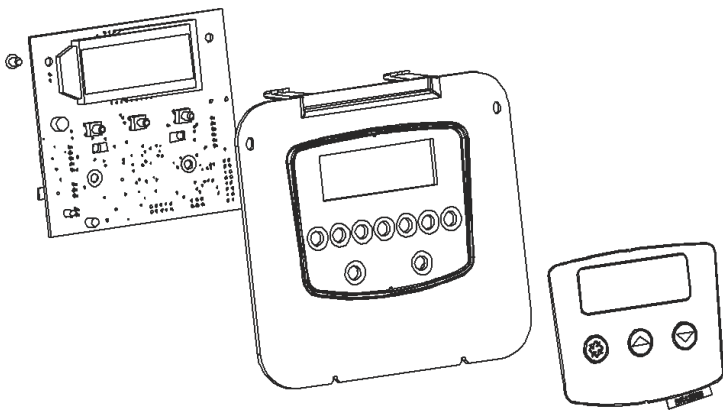
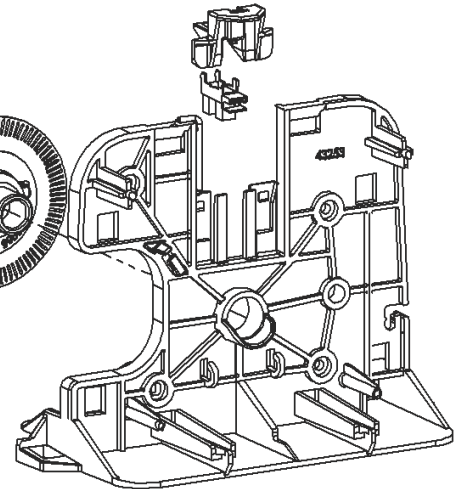
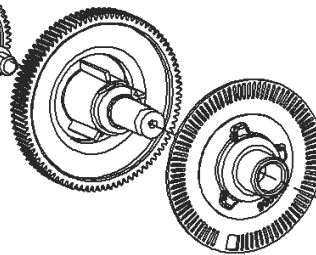

The System must be **BYPASSED, DEPRESSURIZED** and **DE-ENERGIZED** before disassembling or performing mechanical repairs



Disassembly, Repair/Replacement/ Reassembly should only be performed by properly trained service personnel

Powerhead Assembly XTR2

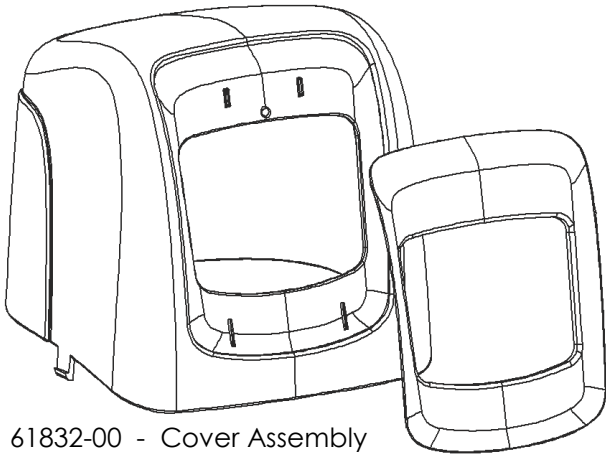

61832-00 - Cover Assembly

61835 - Motor Assembly

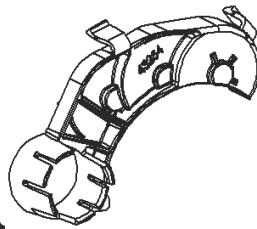
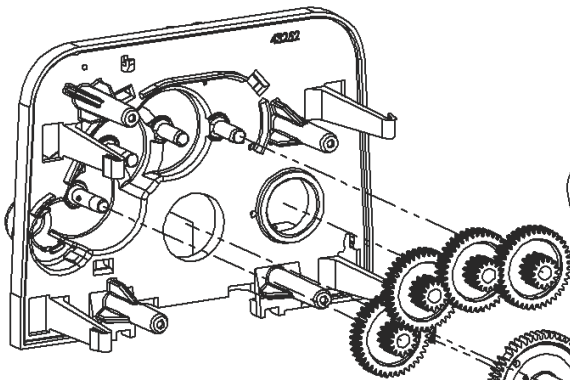
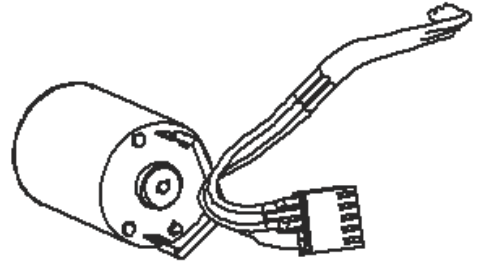

61836 - Panel Gear Assembly, Downflow/ Upflow

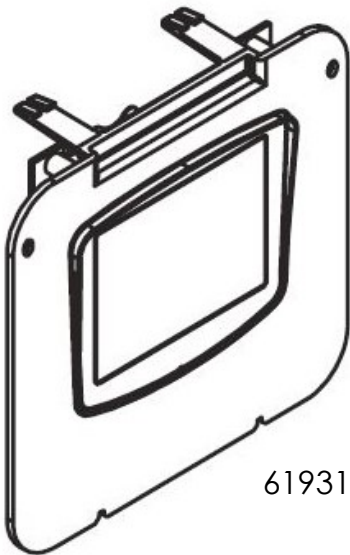
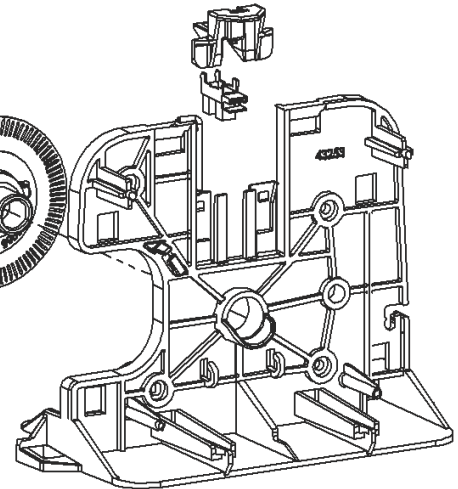
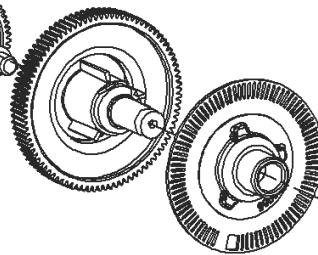

61931-02 XTR2 LCD Touchscreen Controller Assembly



The System must be **BYPASSED, DEPRESSURIZED** and **DE-ENERGIZED** before disassembling or performing mechanical repairs



Disassembly, Repair/Replacement/ Reassembly should only be performed by properly trained service personnel

Circuit Board Overview— XTR2

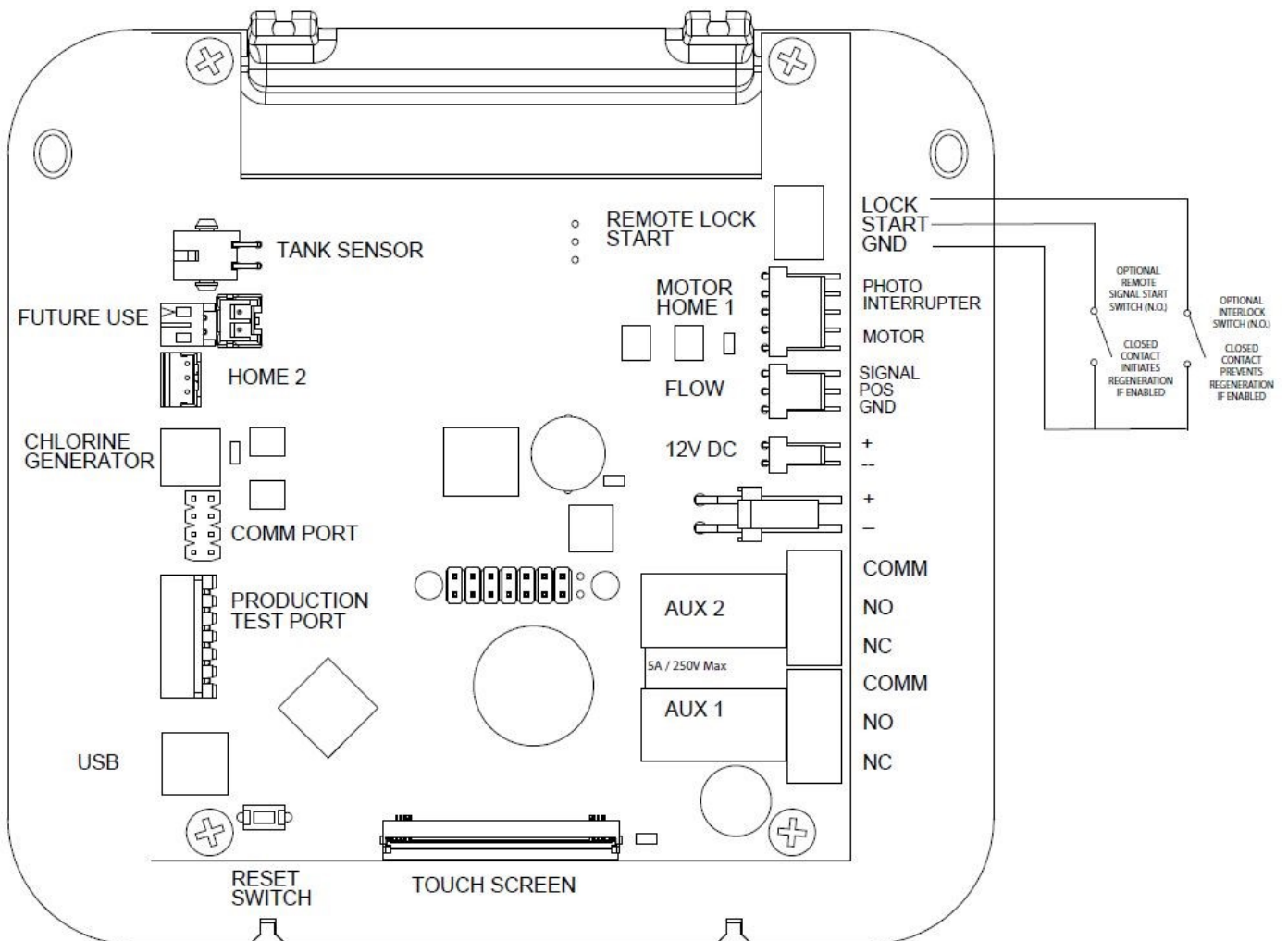

NOTE:

The reset switch discharges the super capacitor when power is removed from the circuit board. The super capacitor retains the current time of day in the event of a power failure for up to 6 hours (depending on age and ambient temperature).

Pressing the reset switch on the circuit board while power is applied to the control will have no effect on the control or stored settings.

5800 Control Valve Assembly

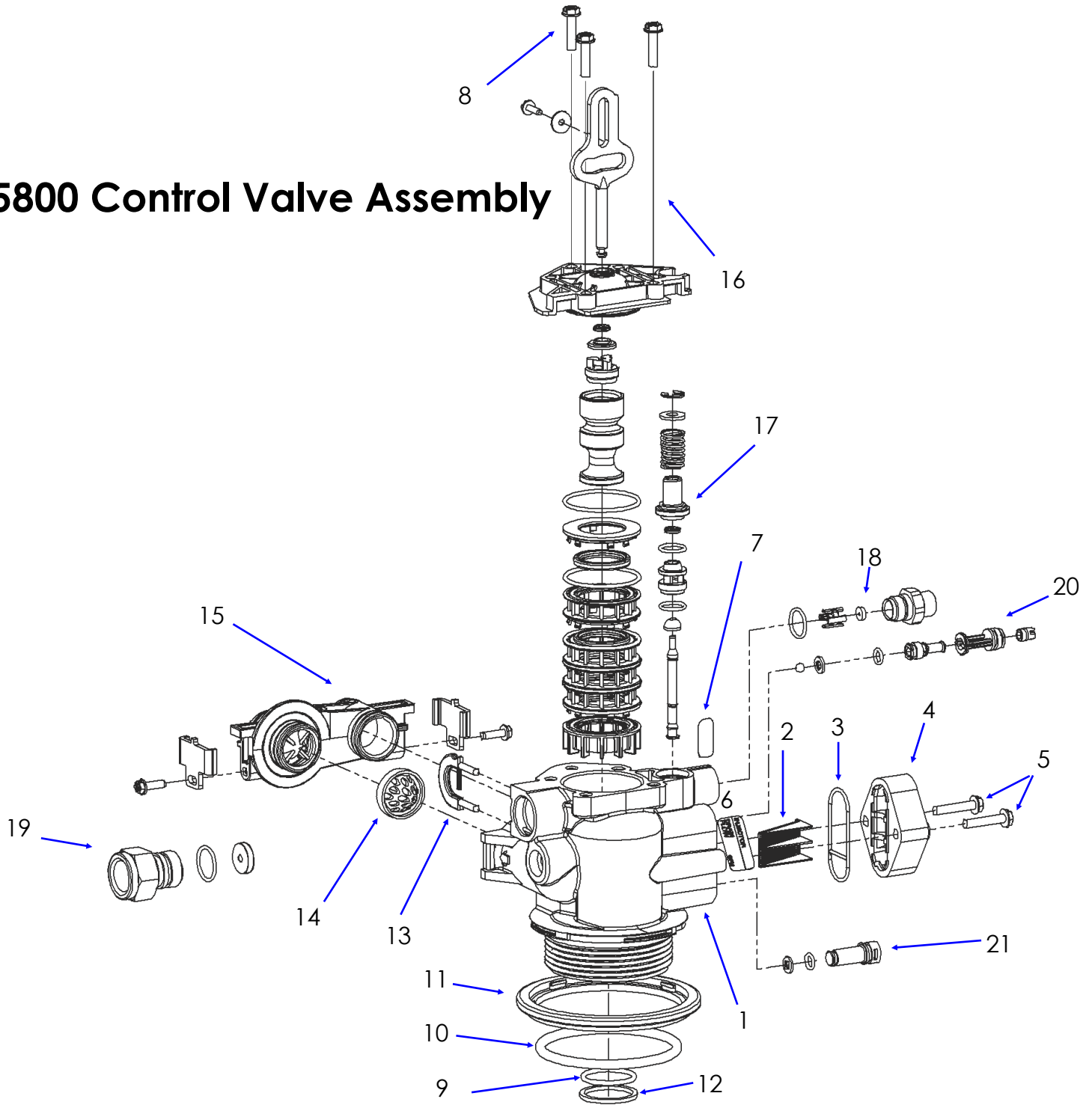

To bypass the system, turn bypass knob on both sides of the valve to bypass position. When returning to service, put the inlet into service before the outlet.



The System must be **BYPASSED, DEPRESSURIZED** and **DE-ENERGIZED** before disassembling or performing mechanical repairs



Disassembly, Repair/Replacement/ Reassembly should only be performed by properly trained service personnel

Control Valve Assembly

Item #	Qty	Part #	Description
1	1	61857-20	Valve Body Assembly (Includes Items 9, 10, 11 and 12)
2	1	18271	Injector Screen
3	1	40064	Injector Seal
4	1	18278-30	Injector Cap Assembly
5	2	18262	Screw, Hex Washer Head, #10-24 x 1.00
6	1	10759	BLFC Label—0,25GPM
7	1	13333	Injector Label
8	3	18261	Screw, Hex Washer Head, #10-24 x 0.81
9	1	13304	O-ring –121
10	1	18303-01	O-ring –336
11	1	18589	Tank seal retainer
12	1	13030	Distributor tube O-ring retainer
13	1	18312	Retaining Cup
14	1	14613	Flow Straightener
15	1	60628	Electronic meter turbine assembly
16	1	61838	Upflow piston assembly
17	1	60032	Brine valve assembly
18	1	60022-25	Brine Line Flow Control
19	1	60705-24	Drain Line Flow Control—2.4 GPM
20	1	18272-0	Injector Assembly 1610 #0
21	1	18276-01	Injector plug assembly with o-ring



The System must be BYPASSED, DEPRESSURIZED and DE-ENERGIZED before disassembling or performing mechanical repairs



Disassembly, Repair/Replacement/ Reassembly should only be performed by properly trained service personnel

5810 Control Valve Assembly

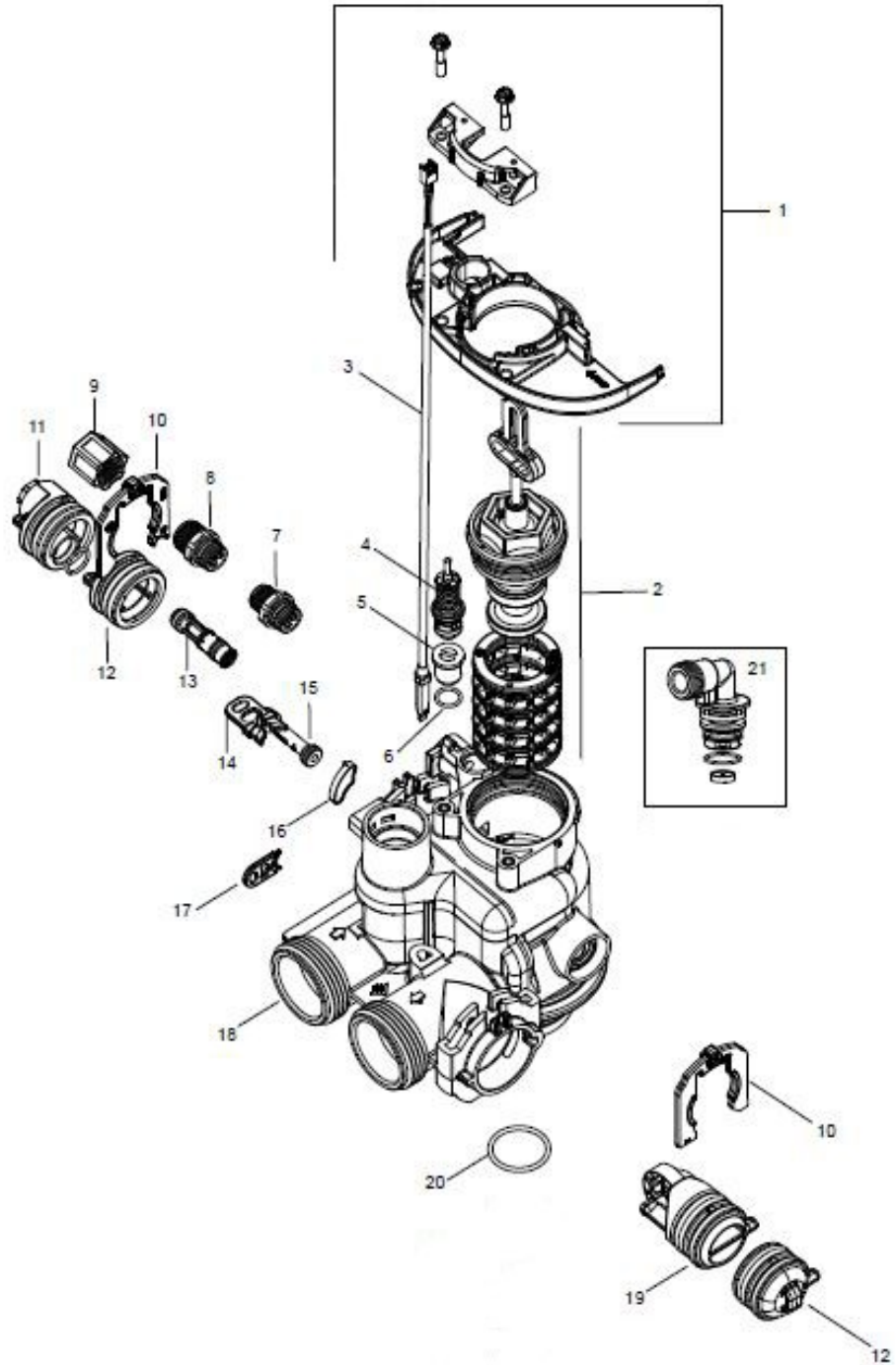

To bypass the system, turn bypass knob on both sides of the valve to bypass position. When returning to service, put the inlet into service before the outlet.



The System must be **BYPASSED, DEPRESSURIZED** and **DE-ENERGIZED** before disassembling or performing mechanical repairs



Disassembly, Repair/Replacement/ Reassembly should only be performed by properly trained service personnel

Control Valve Assembly

Item #	Qty	Part #	Description
1	1	61961	Kit, Mounting, 5810/5812
2	1	61956-02	Kit, Piston, Seal, and Spacer, 5810/5812, Upflow
3	1	19791-01	Meter Cable and Hall-Effect Sensor
4	1	60016	Brine Valve
5	1	40947	Brine Valve Plug
6	1	13302	O-ring -014
7	1	61450-25	Brine Line Flow Control Assembly 0.25 GPM
8	1	OPTIONAL	1/2" Brine Line Floc Control Assembly
9	1	41056	1/2" Nut Assembly
10	1	40576	Plastic retaining clip
11	1	OPTIONAL	Pressure regulated injector cap
12	1	61958	Injector cap assembly with O-ring
13	1	VARIABLES	Injector Assembly—Flow rate varies by model
14	1	40945	Drain retaining clip
15	1	61959	Injector plug with O-rings
16	1	43719	Injector Screen
17	1	40946	Brine retaining clip
18	1	61983-01	5810 Valve Body Assembly
19	1	61919	1.25" Meter Assembly
20	1	19054	O-ring -124
21	1	VARIABLES	Drain elbow assembly—Flow rate varies by model



The System must be BYPASSED, DEPRESSURIZED and DE-ENERGIZED before disassembling or performing mechanical repairs



Disassembly, Repair/Replacement/ Reassembly should only be performed by properly trained service personnel

Brine Tank

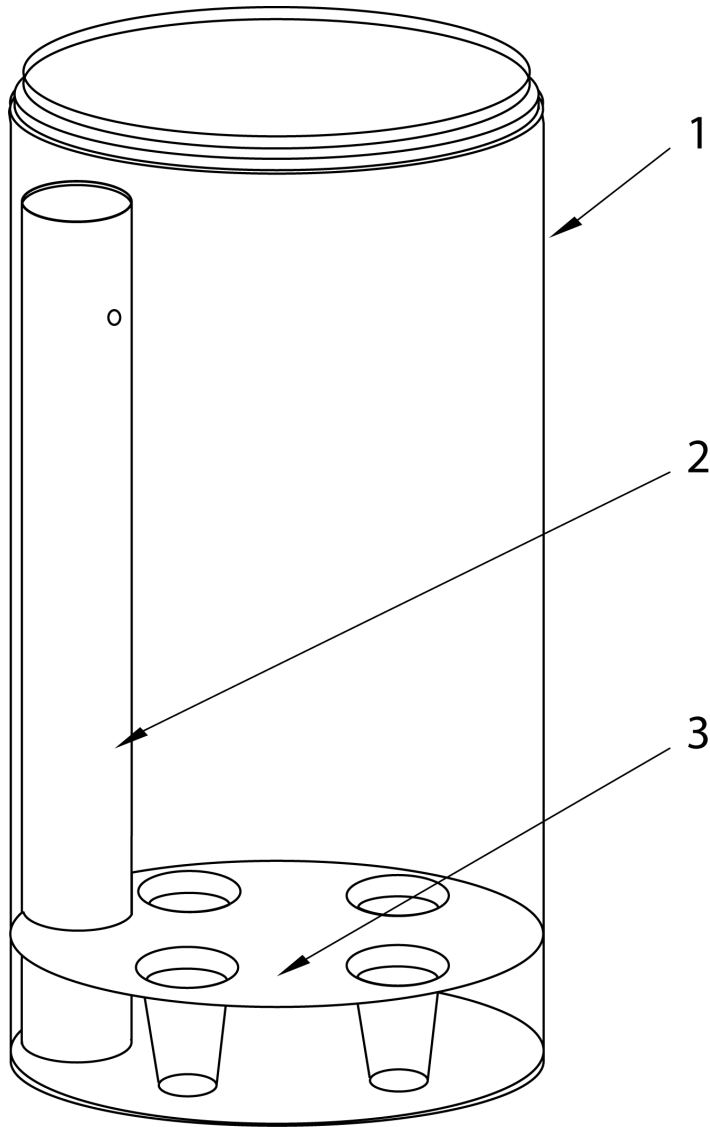

Item #	Qty	Part #	Description
1	1	BT0001	Brine Tank Shell—18x33
2	1	BT0002	Brine Well—18x33
3	1	BT0003	OPTIONAL—Brine Deck



The System must be BYPASSED, DEPRESSURIZED and DE-ENERGIZED before disassembling or performing mechanical repairs



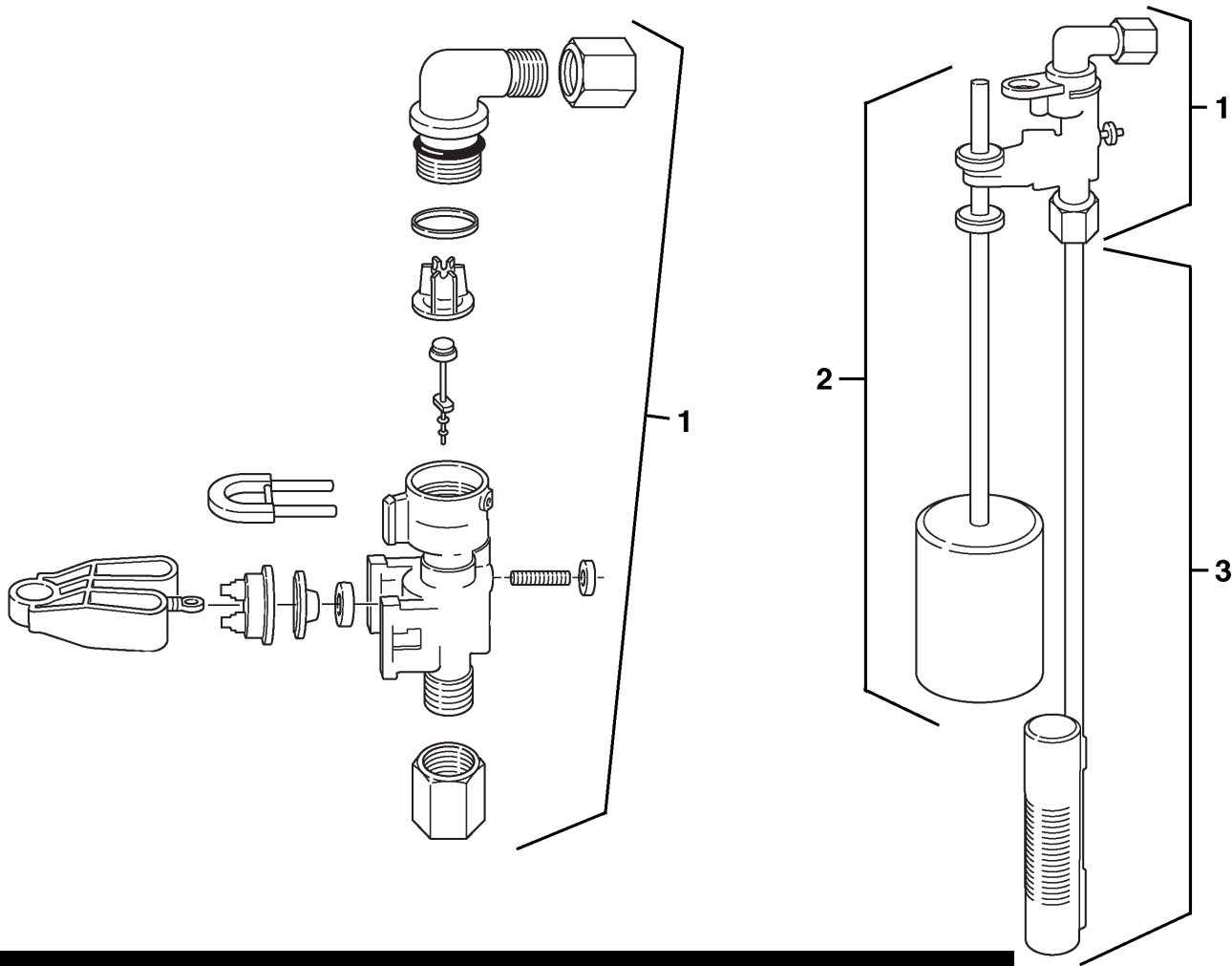

Disassembly, Repair/Replacement/ Reassembly should only be performed by properly trained service personnel

Safety Brine Valve



Item #	Qty	Part #	Description
1	1	60014	Safety Brine Valve Assembly
2	1	60068	Float Assembly
3	1	60002	Air Check Assembly

	<p>The System must be BYPASSED, DEPRESSURIZED and DE-ENERGIZED before disassembling or performing mechanical repairs</p>		<p>Disassembly, Repair/Replacement/ Reassembly should only be performed by properly trained service personnel</p>
---	---	---	--

ProGuard Feeder

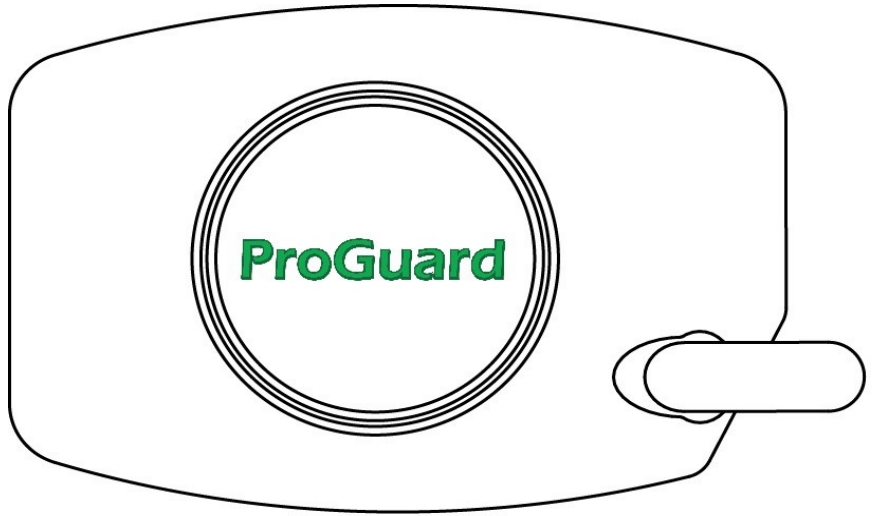

Item #	Qty	Part #	Description
1	1	PFPG01	ProGuard Feeder—1.0

	<p>The System must be BYPASSED, DEPRESSURIZED and DE-ENERGIZED before disassembling or performing mechanical repairs</p>		<p>Disassembly, Repair/Replacement/ Reassembly should only be performed by properly trained service personnel</p>
--	---	--	--



Recommended Cleaning & Disinfection Schedule

Your Crusader Water Improvement System is quite probably the hardest working appliance in your home, processing millions of gallons of water over its service life and in turn protecting you from countless amounts of inorganic calcium, magnesium, lead, copper, zinc, iron, manganese, and other contaminants that could be in your water.

Your softener also accumulates sediment bacteria, algae, mold, and fungus that can enter the system through safe city water, salt, or even from the air. These contaminants slowly accumulate in your softener and can colonize it with a biofilm of Heterotrophic Plate Count bacteria (HPC). These bacteria are usually benign, but can create a food base for potentially harmful pathogens and seriously compromise the longevity and performance of your system. While weekly antibacterial rinses and supplementation with ProGuard help minimize bacterial growth, your system should be cleaned and disinfected on a regular schedule to ensure that it is working to the best of its ability and to protect the safety of your family. This chart shows the recommended monthly cleaning interval.

WATER HARDNESS	PEOPLE IN HOME					
	1	2	3	4	5	6
1	12	12	12	12	12	12
5	12	12	12	12	12	12
10	12	12	12	12	12	12
15	12	12	12	12	12	12
20	12	12	12	12	12	12
25	12	12	12	6	6	6
30	12	12	6	6	6	6
40	12	12	6	6	6	6

Your local dealer can perform the cleaning and disinfection service for you, or you can purchase a comprehensive cleaning and disinfection kit to perform this task yourself.

	The System must be BYPASSED, DEPRESSURIZED and DE-ENERGIZED before disassembling or performing mechanical repairs		Disassembly, Repair/Replacement/ Reassembly should only be performed by properly trained service personnel
---	--	---	---

STATEMENT OF LIMITED PRODUCT WARRANTY

1st year of ownership

This residential water system is warranted as to workmanship and material for a period of one year from date of original installation at the original installation site, if properly installed by a Certified Installer. Should any component in your system prove defective in the first year, it will be repaired, rebuilt or replaced at our option, provided it is returned directly to us.

After the 1st year of ownership, and for 5 more years: should any component in your system prove defective, it will be repaired, rebuilt or replaced at our option for a maximum charge of \$50.00, provided it is returned directly to us. Labor, transportation, shipping or other charges incurred in the diagnosis, replacement or repair of defective components are not covered by this warranty. If you choose not to send a defective component back to us, repairs to your system can be conducted in your home by a factory authorized service technician if your home is within the operating radius of an authorized repair center. This warranty does not cover transportation, shipping, diagnosis, replacement and repair charges resulting from your in-home repair request. We will not be held responsible for loss or damage caused by any defective component.

Conditions

This warranty must be presented at time of claim and all claims must be presented within 30 days of occurrence.

This warranty is void if your water system is not installed in compliance with prevailing plumbing codes, according to our installation protocol, or if the influent water temperature is hotter than 90°F or where the static water pressure is less than 25psi, or more than 75psi. Intentional/malicious damage, misuse, neglect, unauthorized modifications or accidental damage to the system is not covered by this warranty. This warranty does not cover damage caused by pressure surges, water hammer, power surges or sags, lightning, fire, flood, freezing, earthquake, acts of God or other casualty.

Wear and Tear

Your water system is subject to normal wear and tear during its usable service life.

Wear and tear is not regarded as a product defect and is not covered by this warranty.

No Liability for Consequential Damages

Unless otherwise required by applicable law, we shall not be liable for any damages whatsoever (including without limitation, lost time, inconvenience, expenses such as telephone calls, labor or material charges incurred in connection with the removal or replacement of the part(s) or product(s), special, incidental, consequential, or indirect damages for personal injury, loss of business profits, business interruption, loss of business information, or any other pecuniary loss) arising out of the use of or inability to use the defective part(s) or product(s), even if we have been advised of the possibility of such damages. Our entire liability under any provision of this Limited Warranty shall be limited to the amount actually paid for the part(s) or product(s).

No Other Warranties:

We specifically disclaim all other warranties; either express or implied, including, but not limited to implied warranties of merchantability and fitness for a particular purpose, with regard to the part(s), product(s) and/or any accompanying written materials. This limited warranty gives you specific legal rights. You may have other rights that vary from state/jurisdiction to state/jurisdiction.

ProGuard

Your water system includes a ProGuard dispensing system. The ProGuard performance-enhancing additive is essential to proper functioning of your system. If ProGuard is not added to the dispensing system at the prescribed interval in your owner's manual, this warranty will be void.

Periodic replacement of media

While built to the highest standards, certain media in your Water System will need to be replaced periodically by your local authorized service agent. Replacement intervals vary depending on your water chemistry and water consumption habits. Consult with your water specialist during your annual cleaning and disinfection service to ensure that you enjoy the very best water quality. Media replacement is not covered under this warranty.

In order for this limited lifetime warranty to be valid, you must:

- Be the original consumer purchaser, and have purchased the water equipment from an authorized reseller, and
- Provide a copy of the original purchase receipt with proof of date and purchase price

This limited warranty is only valid if registered within 10 days of initial installation.

If unregistered, this warranty is only valid for 1 year from the date of original manufacture.

Extended warranties are available—Consult with your Local Clean Water Crusader

Register your warranty now: www.CrusaderWater.com